

A Study of Thermoacoustic Refrigeration System

Pranav Mahamuni^{1*}, Pratik Bhansali¹, Nishank Shah¹, Yash Parikh²

¹(Department of Mechanical Engineering, Sinhgad Institute of Technology and Science, Pune, India)

²(Department of Mechanical Engineering, Symbiosis Institute of Technology, Pune, India)

Abstract— In an early 19th century, modern refrigeration technologies were introduced to the world. In the last few decades, the use of refrigeration systems has significantly increased. Currently, Cooling is achieved with vapour compression system that use a specific refrigerant. In recent years, it has been discovered that conventional refrigerants affect the environment adversely. For the safety of the environment, it is necessary to avoid the use of environmentally hazardous refrigerants by developing new alternative refrigeration technologies such as Thermoacoustic Refrigeration System. This paper describes the variation of hot end temperature and the temperature difference between the stack ends with the various parameters like frequency, mean pressure.

Keywords— Refrigeration, Vapour Compression System, Refrigerants, Thermoacoustic Refrigeration System

I. INTRODUCTION

The process of refrigeration means the cooling the desired space and maintaining the temperature below the ambient temperature. Acoustics deals with study of sound production, transmission, and effects. Thermoacoustic deals with thermal effects of the sound waves and the interconversion of sound energy and heat. Sound waves travel in a longitudinal fashion. They travel with successive compression and rarefaction of the medium in which they travel (gaseous medium in this case). This compression and expansion respectively lead to the heating and cooling of the gas. This principle is employed to bring about the refrigeration effect in a thermoacoustic refrigerator.

In Los Alamos National Laboratories (LANL), a team consisting of Gregory W Swift, J. C. Wheatley and Thomas J. Hofler accidentally developed the first modern TAR when they tried to power a heat pump with the help of a Stirling engine [1].

II. CONSTRUCTION AND WORKING OF THERMOACOUSTIC REFRIGERATION SYSTEM

Thermoacoustic Refrigeration System mainly consist of a loudspeaker attached to an acoustic resonator (tube) filled with a gas. In the resonator, a stack consisting of a number of parallel plates and two heat exchangers are installed. The loudspeaker, which acts as the driver, sustains acoustic standing waves in the gas at the fundamental resonance frequency of the resonator. The acoustic standing wave displaces the gas in the channels of the stack while compressing and expanding respectively leading to heating and cooling of the gas. The gas, which is cooled due to expansion absorbs heat from the cold side of the stack and as it subsequently heats up due to compression while moving to the hot side, rejects the heat to the stack. Thus the thermal interaction between the oscillating gas and the surface of the stack generates an acoustic heat pumping action from the cold side to the hot side. The heat exchangers exchange heat with the surroundings, at the cold and hot sides of the stack.

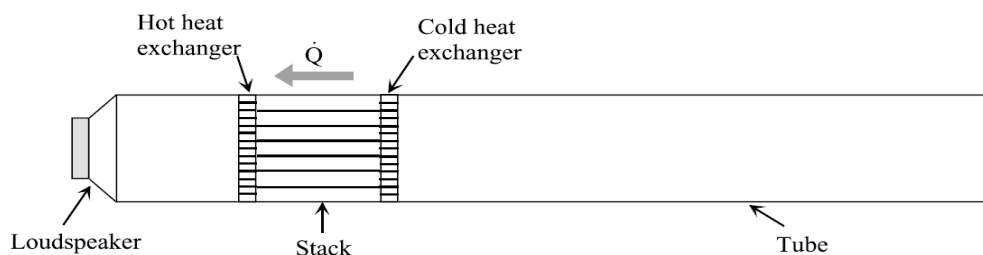

Fig. 1 Schematic representation of construction of thermoacoustic refrigerator.

Fig. 1 shows the schematic representation of the construction of thermoacoustic refrigerator where the loudspeaker is used as a driver, the resonance tube sustains the standing wave.

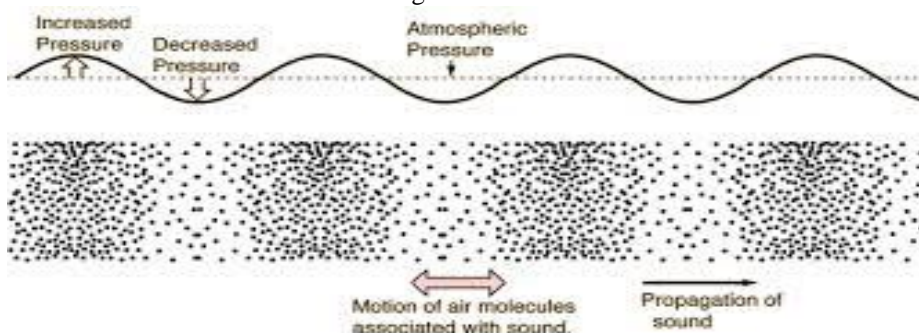

Fig. 2 Pressure variation and displacement of sound waves.

The heat exchangers are used so that heat interaction with the surrounding takes place. Heat is pumped from the cold end heat exchanger to the hot end heat exchanger.[2] Fig. 1 shows the pressure variation and displacement of sound waves in thermoacoustic refrigeration system [5]. It is known that sound waves are longitudinal waves. They produce compression and rarefaction in the medium they travel. Maximum pressure occurs at the point of zero velocity and minimum pressure at maximum velocity.

III. COMPARISON OF THERMOACOUSTIC REFRIGERATION SYSTEM WITH OTHER REFRIGERATION SYSTEMS

Apart from vapour compression devices, there are several other ways to provide cooling and refrigeration. Although none of these are currently as versatile as a Vapour Compression Systems but some of these systems hold a high possibility of replacing the pollution causing Vapour Compression Systems. Comparison with various systems is as follows [3].

A. Type of Refrigerant

The Absorption Refrigeration uses a binary mixture of refrigerant and absorbent like Water/ammonia or LiBr/water. The Adsorption system uses natural refrigerants like water, ammonia or alcohol. Thermo-electric and Thermoacoustic Refrigeration Systems do not use any refrigerant.

B. Working Cycle

Vapour Absorption Refrigeration is a two stage process. The vapour refrigerant is absorbed in a binary solution which then regenerates the refrigerant on heating externally. It is cooled in the condenser to the required pressure level and the cycle repeats. Much like the Vapour Compression Refrigeration Systems the Adsorption Systems are also based on withdrawing heat from surroundings during an evaporation process. Thermo-electric System is based on the Peltier Effect wherein an electric current passing through a junction of two materials will cause a change in temperature. The Thermoacoustic Refrigeration System is powered by either a heat engine running on waste heat or an electric source. Due to compression and expansion of air packets heat transfer across two mediums is made possible.

IV. CASE STUDY

It is important to consider the adverse effect of environmental hazardous refrigerants while designing and development of refrigerating systems so it is necessary to avoid the use hazardous refrigerants by using alternative refrigeration technologies like Thermoacoustic Refrigeration which produces cooling from sound.

The detailed study of the performance of thermoacoustic refrigeration system described in this paper is reviewed from Emmanuel et al. [4]

A. Specifications of Thermoacoustic Refrigeration System

To reduce the heat loss by conduction, resonator tube was constructed from aluminium tubing with plastic tubing at inner portion. Helium was used as the working fluid. Parallel type stack made from thermoplastic was used for this study.

The Fig. 3 shows the geometry and different views of stack with the plates arranged in parallel.

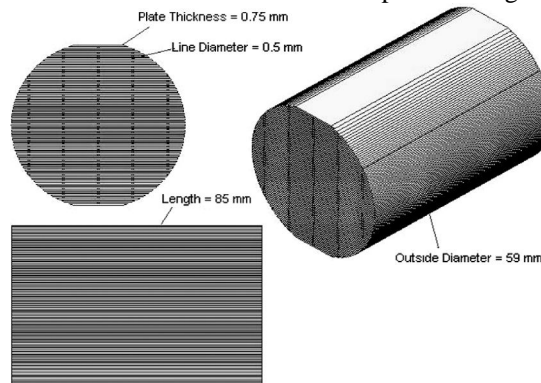

Fig. 3 Views of parallel plate stack arrangement

For the design and operation of this thermoacoustic refrigeration system, used parameters are as follows

- Speed of sound in gas – 1013 m/s
- Gas specific heat – 5193 J/KgK
- Gas thermal diffusivity – $13.2 \times 10^{-5} \text{ m}^2/\text{s}$
- Gas thermal conductivity – 0.155 W/mK
- Gas dynamic viscosity – $197 \times 10^{-7} \text{ Ns/m}^2$
- Gas density – 0.8845 Kg/m³
- Drive ratio – 0.02
- Ratio of specific heats – 1.67
- Normalized stack length – 0.262
- Blockage ratio – 0.5

The thermo physical properties of helium given above are with respect to standard pressure and temperature conditions.

B. Experimental Testing Setup

Experimental setup consists of a Thermoacoustic Refrigeration System, Test Section, and Data Acquisition system

1) Thermoacoustic Refrigeration System

The Thermoacoustic Refrigeration System includes resonator tube, stack, acoustic driver and heat exchanger.

2) Test Section

Test section involves measurement of temperatures at the inlet and outlet of the heat exchanger, at the middle of resonator, at the surface of acoustic heater and near the electric heater with the help of thermocouples.

3) Data Acquisition System

The Data Acquisition System consists of thermocouples, transducer, oscilloscope, flow meter, data acquisition board and personal computer for the data display.

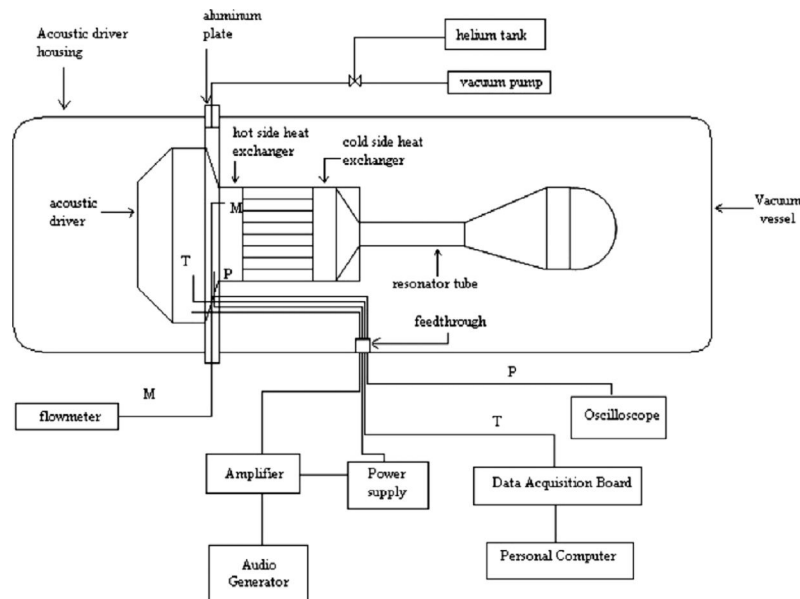

Fig. 4 Diagram of an experimental setup

C. Experimental Testing Procedure

The experimentation was done to study the performance of the system under various operating conditions like mean pressure, frequency and cooling load. The mean pressure was initially set at 3 bars. The frequency was changed slowly as desired for each set of experiments. On the cold side heat exchanger, resistance heating was used to change the cooling load. First the data were taken from the initial time till steady condition was reached. After this, the frequency was set to a higher level and the data were recorded in the above manner. After this was done for the entire frequency range, the pressure was changed to 4 bars and the procedure was repeated for this pressure level. Similarly the data was recorded for the next pressure levels, i.e. 5 and 6 bars. After this was done, a similar experiment was done for different cooling loads. This experimentation thus gave the results for various operational parameters.

D. Result and Discussion

1) Effect of Various Frequencies on Performance of Thermoacoustic Refrigeration System

This section shows the performance of Thermoacoustic Refrigeration System by changing frequency and taking constant mean pressure and cooling load.

The various frequencies used are as follows: 250 Hz, 300 Hz, 350 Hz, 400 Hz, 450 Hz, and 500 Hz.

The Fig. 5 Shows that the graph of temperature at hot end of the stack with time for various frequencies at constant mean pressure and cooling load. From Fig. 5, it is clear that the temperature at hot end of stack initially increased and then became stable. This stability time increased with the increased in pressure, this is because as the mean pressure increases thermoacoustic effect increases.

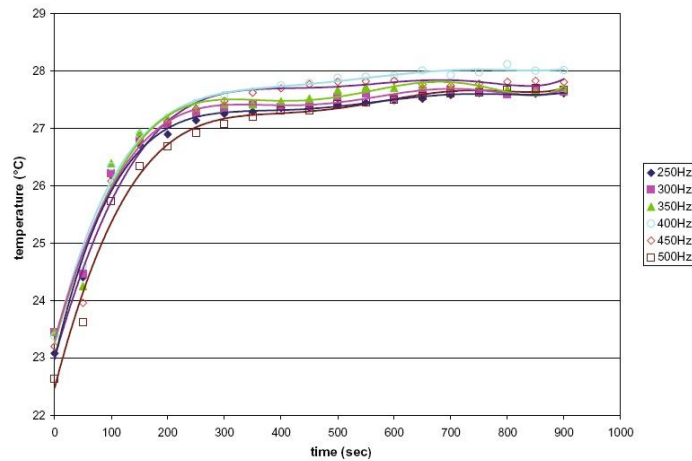

Fig. 5 Stack hot end temperature-time history for constant cooling load and mean pressure for various frequencies.

2) Effect of Changing Cooling Load on Performance of Thermoacoustic Refrigeration System

This section shows the performance of Thermoacoustic Refrigeration System by changing cooling loads and taking constant pressure and frequency.

The experiment was done for cooling loads of 1 W, 2 W, 3 W & 4 W.

- Stack Hot Temperature – Time History

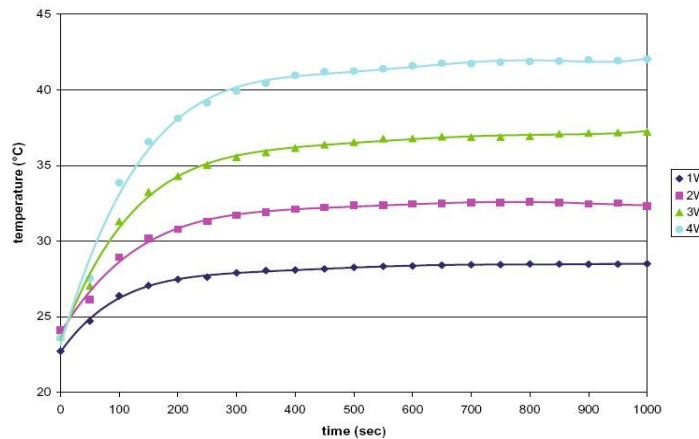

Fig. 6 Stack hot end temperature - time history for constant mean pressure and frequency for various cooling loads

The Fig. 6 shows the variation of stack hot end temperature with time for different cooling powers. From Fig. 6, it is concluded that as the cooling load increases more heat is pumped leading to increase in hot end temperature of the stack and more time required to reach equilibrium position in the system.

- Stack Hot Temperature – Frequency

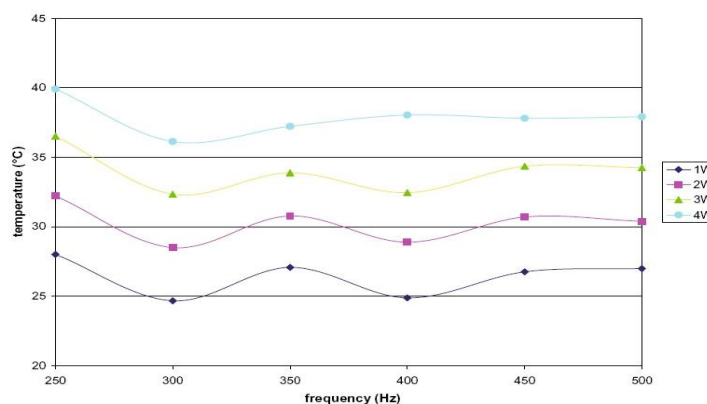

Fig. 7 Stack hot end temperature - frequency at constant mean pressure for various cooling loads

Fig. 7 shows that the relationship between temperature and frequency at constant mean pressure for various cooling loads. From Figure 7, it is concluded that as the cooling load increases, the hot side temperature of the resonator also increases.

The Fig. 7 also shows the sinusoidal nature of the graph, it is because of the oscillating nature of the gas flow in the system

3) Effect of Mean Pressure on Performance of Thermoacoustic Refrigeration System

This section shows the performance of a Thermoacoustic Refrigeration System for constant cooling load and frequency with variation in mean pressure.

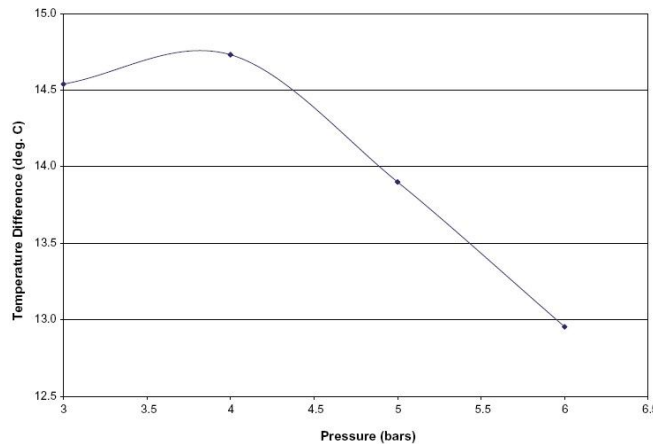

Fig. 8 Temperature difference between the ends of the stack at constant frequency vs mean pressure in the system

Fig. 8 shows that the relationship between stack ends and the pressure. From Fig. 8, it is concluded that with the increase in pressure, initially the temperature difference increases and it becomes maximum around 4 bars, then decreases linearly so there exists a value of pressure where the temperature difference is maximum. It is also concluded from the figure that the maximum pressure does not imply that the temperature difference is maximum.

V. CONCLUSION

The Thermoacoustic Refrigeration System consists of no moving parts. Hence the maintenance cost is also low. The system is not bulky. It doesn't use any refrigerant and hence has no polluting effects. From the case study, it is observed that cooling power is dependent on working frequency, cooling load and pressure. It is also observed that for best performance of the system, it is necessary to choose operating parameters wisely. This paper can be used as a reference for design, understanding and improvement in the Thermoacoustic Refrigeration System.

ACKNOWLEDGMENT

The authors would like to present their sincere gratitude towards the Faculty of Mechanical Engineering in Sinhgad Institute of Technology and Science, Pune and Symbiosis Institute of Technology, Pune.

REFERENCES

- [1] G.W. Swift, "What is thermoacoustics? A brief description". Condensed Matter and Thermal Physics Group. Los Alamos National Laboratory, Los Alamos, New Mexico. 2004.
- [2] M.E.H. Tijani, J.C.H. Zeegers, A.T.A.M. de Waele, "Design of thermoacoustic refrigerators". Elsevier, Cryogenics 42 (2002) 49-57.
- [3] F. Zink, J. S. Viperman, L. A. Schaefer, "Environmental motivation to switch to thermoacoustic refrigeration". Applied Thermal Engineering 30 (2010) 119-126.
- [4] E. C. Nsofor, A. Ali, "Experimental study on the performance of the thermoacoustic refrigerating system". Applied Thermal Engineering 29 (2009) 2672-2679.
- [5] <http://hyperphysics.phy-astr.gsu.edu/hbase/sound/tralon.html>