

# High Step-Up DC-DC Converter

Praful Vijay Nandankar.

Department of Electrical Engineering,  
Rashtrasanth Tukdoji Maharaj Nagpur University

Abhilash Nilkanth Fating

Department of Electrical Engineering  
Rashtrasanth Tukdoji Maharaj Nagpur University

**Abstract - This paper proposes a transformer-less high step-up DC-DC converter which acts as an interconnection between DC systems. A new step up converter proposed in the paper is designed and simulated in a simulation environment. The conventional boost converter cannot have any control over the input current at a high duty cycle. Due to which, it draws considerable amount of current from the source which can create problems for the components used in DC-DC converter. Moreover, the voltage stress across the switch comes nearly equal to output voltage. These problems can be overcome in the proposed topology discussed in the paper. The improved topology enhances important electrical parameters such as voltage gain, power loss and switch voltage stress. These improvements in the parameters are explained with the help of formulae explained in the paper. The improved topology improves the voltage stress and voltage gain. The output voltage is modified with the introduction of extra components. Due to improvement in these parameters, the proposed topology becomes an attractive feature for use with DG systems. The comparison is performed between conventional boost converter and boost converter with improved topology. The efficiency curves are plotted for simple boost converter and improved topology. The efficiency is evaluated for a wide range of duty cycle and this confirms the effectiveness of the improved topology discussed in the paper. The proposed converter design and its implementation are given with operational results. The simulation results are tested for an input voltage of 12V. The input voltage is stepped up to output voltage of 100V which can be used for various applications. The interfacing problem of DG system (PV cell arrays) with grid will solve using this methodology.**

**Keywords- high voltage gain, high step-up, DC-DC converter**

## I. INTRODUCTION

Energy consumption is tending to grow continuously. This demand is satisfied against a background of the depletion of conventional fossil resources. The renewable energy sources are becoming more and more popular. Global investments and R&D efforts are concentrating to reduce the renewable energy cost.

High gain boost converters are the key part of renewable energy systems. Boost converters are the converters with the dc output voltage greater than its input dc voltage. It is a class of switching mode power supply (SMPS) containing at least two semiconductor switches (a diode and a transistor) and at least one energy storage element. Filters made of capacitors (sometimes in combination with inductors) are normally added to the output of the converters to reduce output voltage ripple. This converter has the advantages of simplicity and high efficiency. This converter is transformer-less and thus has the desirable features of high efficiency, low cost and small size. Boost converters do not require isolation which is used in many applications. For example, DC back energy systems for UPS, fuel cell systems, renewable energy systems etc. To use boost converters it has the following requirements:-

1. High step up voltage gain.
2. High current handling capability.
3. High efficiency of a desired level of volume and weight.
4. Low input current ripple.

To provide high output voltage, the boost converter should operate at extremely duty cycle and then diode must sustain a short pulse current with high amplitude. By using extreme duty cycle may also lead to poor dynamic responses to line and load variations as well as results in serious reverse recovery problem. The basic boost converter is a very simple structure with a high step-up voltage gain, but the active switch of this converter will suffer a high voltage stress. The input current is large in the boost converter and hence low voltage rated MOSFET's with small  $R_{ds(ON)}$  are necessary in order to reduce the dominating conduction loss. The switch in the boost converter should sustain high output voltage as well and therefore the device selection is faced with a contradiction. High step up boost converter topology have been presented to overcome the problem. Basically boost converter is a power converter with an output dc voltage greater than its input DC voltage. The operation of the boost converter is to boost up a certain input voltage to a higher level at the same time the boost converter steps down the current as a natural result of the energy conservation principle which implies that power being the product of voltage and current must be conserved.

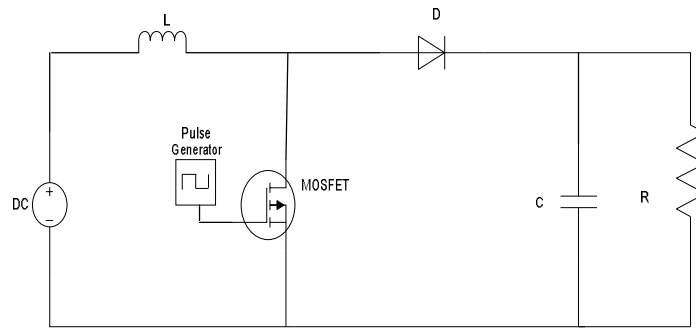

Fig1. Simple Boost converter

The operation of the boost converter is to boost up a certain input voltage to a higher level at the same time the boost converter steps down the current as a natural result of the energy conservation principle which implies that power being the product of voltage and current must be conserved. The boost converter is based on the tendency of an inductor to resist changes in its current. When an inductor is charged, it behaves like a load as it absorbs energy. On the other hand, when it is discharged, it behaves as an energy source. The operation of the boost converter is explained when the switch is closed, the inductor is charged its current increases. When the switch is open, the only path offered to inductor current is through the diode D, the capacitor C and the load R. It indicates that energy generated during the ON state is transferred into the capacitor. The operation of boost converter is explained below. It includes two distinct stages:

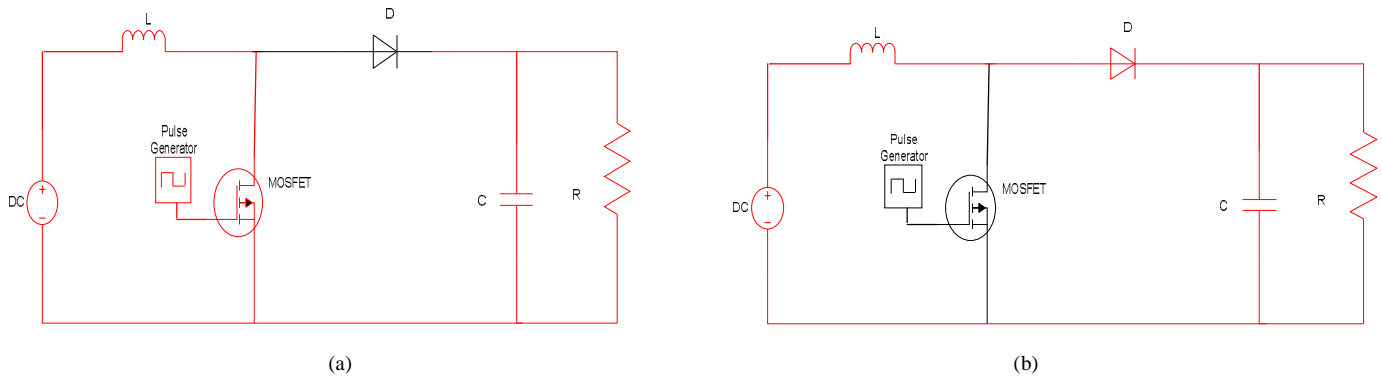

Fig. 2. (a) In an ON state and (b) OFF state

On-state: in which the switch is closed, and thus the inductor is charged, i.e., its current increases. Off-state: the switch is open and the only path offered to inductor current is through the diode D, the capacitor C and the load R. This result in transferring the energy accumulated into the capacitor during the on-state.

## II. IMPROVED TOPOLOGY WITH ITS OPERATION

### A. Circuit Topology

From basic topology we get voltage gain and in this topology we get increase in voltage gain. In fact, this converter uses two inductors of the same inductance level and the two switches being simultaneously used. When the switch is on, diode becomes forward biased, capacitor and inductor gets charged and then load discharges. When the switch is off, diode becomes forward biased and stored energy in an inductor gets transferred to the capacitor.

The operation as follows:-

Stage 1: This stage extends from  $t_0$  to  $t_1$  as shown in figure. In this interval, both the switches are turned on, and the equivalent circuit is shown in figure. During this stage both the inductors are charged in parallel whereas capacitor  $C_0$  releases its energy to the load. Moreover capacitors  $C_1$  and  $C_2$  are charged from the DC source.

The voltage across  $L_1$ ,  $L_2$ ,  $C_1$  and  $C_2$  are given by:

$$V_{L1} = V_{L2} = V_{in} = V_{C1} = V_{C2} \quad (1)$$

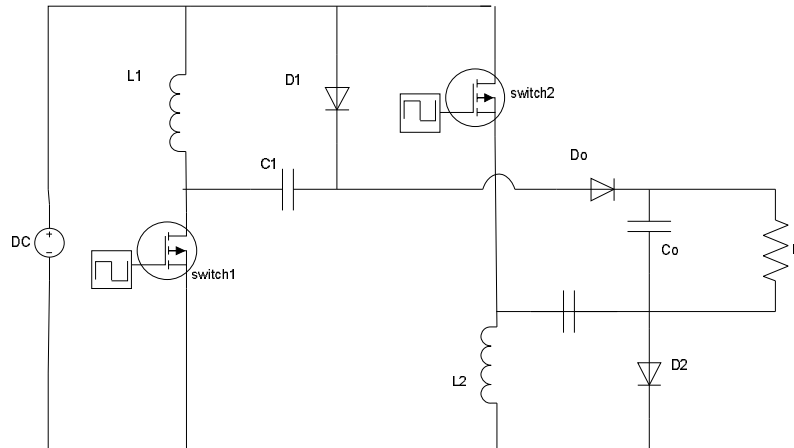

Fig. 3. Improved Circuit Topology

*B. Circuit Operation*

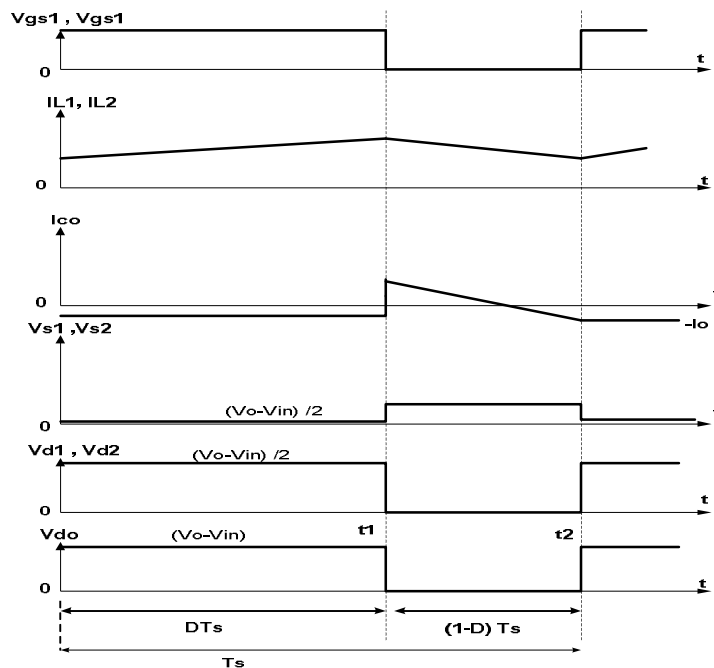

Fig. 4. Voltage and Current Waveforms for Improved Circuit Topology

Stage 2: This stage extends from  $t_1$  to  $t_2$  as shown in figure. In this stage both the switches are turned off and the equivalent circuit is shown in figure. Besides,  $L_1$ ,  $L_2$ ,  $C_1$  and  $C_2$  are connected to the DC source in order to transfer the stored energy to  $C_0$  and load. So, the voltage across  $L_1$  and  $L_2$  are given by:

$$V_{L1} = V_{L2} = \frac{V_{in} + V_{C1} + V_{C2} - V_o}{2} = \frac{3V_{in} - V_o}{2} \quad (2)$$

The two inductors are equal in values and have the same current. The voltage gain can be evaluated as:

$$\int_0^{DT_s} V_{in} dt + \int_{DT_s}^{T_s} \frac{3V_{in} - V_o}{2} dt = 0 \quad (3)$$

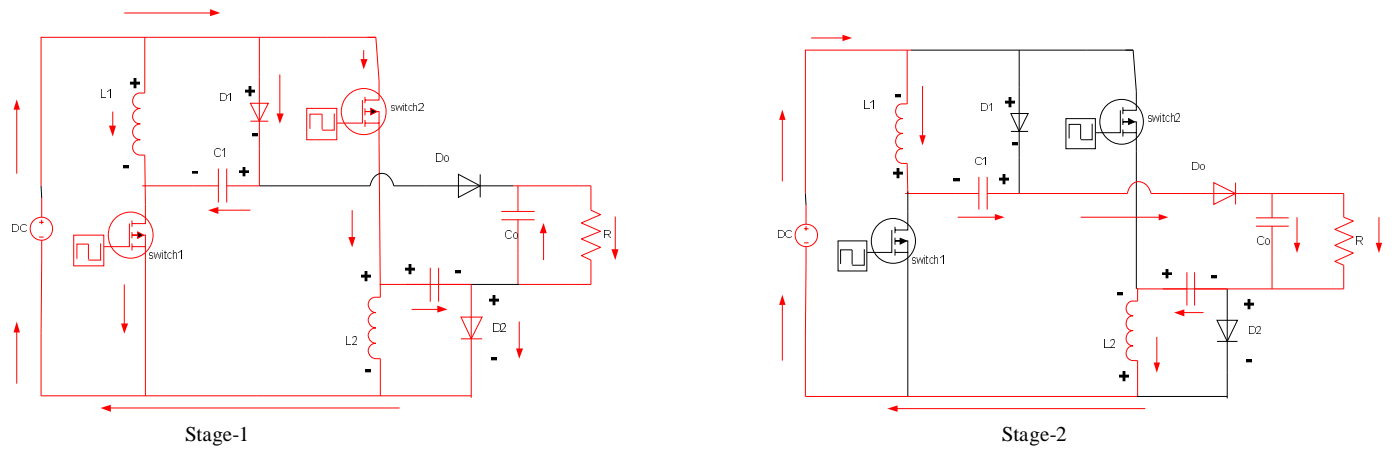

Fig. 5. Equivalent circuit of stage-1 and stage-2 of Improved Topology

The voltage gain is thus derived by rearranging the above equation, as follows:

$$\frac{V_o}{V_{in}} = \frac{3-D}{1-D} \quad (4)$$

where, D is the duty cycle.

The voltages of the switch are given by:  $V_{S1} = V_{S2} = V_{D1} = V_{D2} = \frac{V_{in} - V_o}{2}$  (5)

Moreover, the diode voltage is:  $V_{D0} = V_o - V_{in}$  (6)

### III. CIRCUIT PERFORMANCE

The improved converter topology has been modeled using simulation. The simulation has been conducted to verify the performance of high step-up DC-DC converter. The circuit with the components indicated in fig.3 are given in Table I and used for evaluating the circuit performance. In the simulation, MOSFET is used as the switching device.

TABLE I: Circuit Parameters for Analysis

Parameters	Values
Inductor ( $L_1$ )	60 $\mu$ H
Inductor ( $L_2$ )	60 $\mu$ H
Capacitor ( $C_1$ )	80 $\mu$ F
Capacitor ( $C_2$ )	80 $\mu$ F
Output Capacitance ( $C_o$ )	100 $\mu$ F

#### A. High Step up DC-DC Converter Performance

The simulated output voltage at 100 kHz switching frequency is shown in fig. 6(a). The improved converter is tested for 12V input and 100V output is obtained. The switching frequency of switches are kept at 100 kHz switching frequency. Due to high frequency operation, the size of inductors  $L_1$  and  $L_2$  are reduced. The average value of inductor currents  $i_{L1}$  and  $i_{L2}$  are obtained as 1.5A. The decrease in the input current at a high duty cycle holds a greater significance. The improved converter can be operated at a high duty cycle without an enormous amount of input current. The output is maintained its constant value of 100V for various loading conditions.

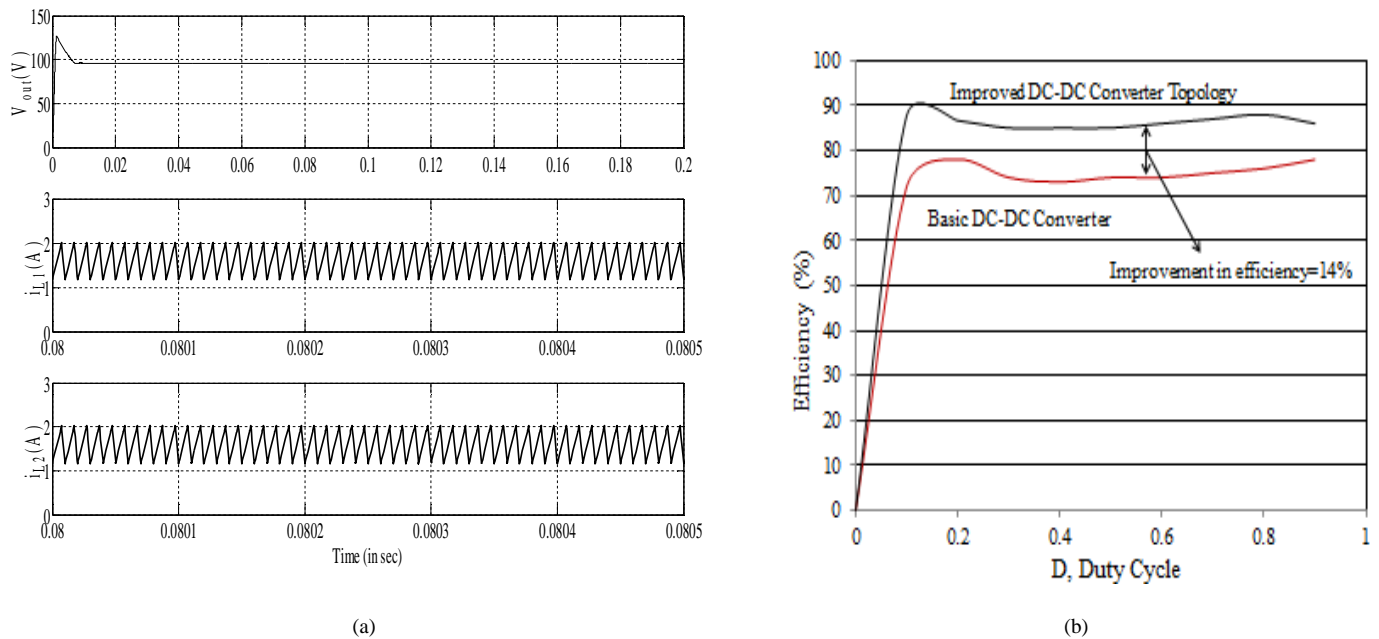

Fig. 6. (a) Output voltage, inductor current through L1 and inductor current through L2 at 100kHz, 12-100V operation, (b) Efficiency curves of basic and improved topology for different values of duty cycle

### B. Improved DC-DC converter efficiency

The efficiency curves for improved DC-DC converter and basic DC-DC converter is obtained for various value of duty cycle as shown in fig. 6(b). The efficiency for improved DC-DC converter and basic DC-DC converter are compared at different values of duty cycle in fig. 6(b). Both the converters are operated at a switching frequency of 100kHz. The efficiency is higher in improved topology as compared to basic DC-DC converter. The % improvement in efficiency from basic to improved is found to be 14%.

## IV. CONCLUSION

The performance of high step up DC-DC converter is given with simulation results. The high voltage gain is obtained without using transformer. The proposed converter has various advantages compared to basic boost converter topology. The output of 100V is obtained from an input voltage of 12V. The problem of high input current at a high duty cycle overcomes in the proposed topology. The average value of inductor currents are obtained around 1.5A. The voltage stress across the switches is considerably reduced by adopting the proposed topology. The efficiency curves for basic and improved converter topology is also presented which indicates the high efficiency of high step-up DC-DC converter. The efficiency of high step-up DC-DC converter gives 88% efficiency under various values of duty cycle shown in efficiency curves. The improvement in energy conversion efficiency is found to be 14% over basic DC-DC converter.

## REFERENCES

- [1] Denis Fewson, *Introduction To Power Electronics*, Oxford University Press, 1998, PP.6-26.
- [2] Lung-Sheng, Tsorng-Juu Liang, —Transformerless DC–DC Converters with High Step-Up Voltage Gain| *IEEE Trans. Ind. Electron*, VOL. 56, NO. 8, pp. 3144 –3152, Aug. 2009.
- [3] Rashid, H. Muhammad, *Power Electronics – Circuits, Devices and Applications*, Prentice Hall India, 2004.
- [4] B. Axelrod, Y. Berkovich, and A. Ioinovici, —Transformerless DC–DC converters with a very high DC line-to-load voltage ratio,| *in Proc. IEEE ISCAS*, 2003, pp. III-435–III-438.
- [5] D. M. Robert W. Erickson, *Fundamentals of Power Electronics*, Second Edition. New York: Kluwar Academic, 2004.