

# Design and Development of a Smart Circuit Fault Monitoring and Protection Framework

K.Prasanth 

Assistant Professor, Department of Electronics and Communication Engineering,  
Sengunthar Engineering College (Autonomous), Tiruchengode, India

[kprasanth.ece@scteng.co.in](mailto:kprasanth.ece@scteng.co.in)

<https://orcid.org/0009-0000-7305-7196>

R.Devendhiran, R.Jeevan prasanth, K.Kubendiran

UG Scholars, Department of Electronics and Communication Engineering,  
Sengunthar Engineering College, Tiruchengode, Tamil Nadu, India



## Publication History

**BibTeX Key:** Prasanth@2026Design

Manuscript Reference No: IJIRAE/RS/Vol.13/Issue03/AEMR26.MRAE10127

Research Article | Open Access | Double-Blind Peer-Reviewed | Article ID:IJIRAE/RS/Vol.13/Issue03/AEMR26.MRAE10127

Received:22,February 2026, Revised: 01, March 2026, Accepted: 16,March 2026,Published Online: 25, March 2026.

<https://www.ijirae.com/volumes/Vol13/iss-03/48.AEMR26.MRAE10127.pdf>

**Article Citation:** Prasanth,Devendhiran,Jeevan,Kubendiran(2026),Design and Development of a Smart Circuit Fault Monitoring and Protection Framework ,IJIRAE: International Journal of Innovative Research in Advanced Engineering, Volume 13, Issue 03 of 2026 pages 392-404 **Doi:**> <https://doi.org/10.26562/ijirae.2026.v1303.48>

IJIRAE papers should be cited as IJIRAE (International Journal of Innovative Research in Advanced Engineering, AM Publications, India 2025, ISSN 2349-2163, <https://doi.org/10.26562/ijirae.2026.v1303.48> The journal's official abbreviation is IJIRAE. **Orcid:** <https://orcid.org/0009-0004-9398-7488>

About the License: Copyright©2026 copyright by the authors. This article is an open access and license under the terms and conditions of the Creative Commons Attribution (CC BY) license (<https://creativecommons.org/licenses/by/4.0/>).

**Abstract:** This work presents the simulation and performance evaluation of an ESP32-based voltage, current, and temperature monitoring and protection system using Proteus. The project aims to design a low-cost, accurate, and intelligent control model that can observe critical electrical and thermal parameters in real time without physical hardware construction. In the simulated circuit, the voltage divider network measures the input supply voltage, the ACS712 current sensor monitors current flow, and the DHT11 sensor provides temperature data. These sensor signals are processed by the ESP32 microcontroller, which performs Analog-to- digital conversion, calibration, and logical decision-making to ensure safe operating conditions. All measured values are displayed on a 16×2 I<sup>2</sup>C LCD for continuous visual observation. The system employs a relay and buzzer for automatic protection and alerting functions: the relay disconnects the simulated load and the buzzer activates when overvoltage, under voltage, or high-temperature situations occur. The simulation environment in Proteus 8 accurately represents sensor behaviour, microcontroller responses, and output actions, allowing complete testing of the algorithm before practical deployment. Results from the simulation confirm that the proposed design performs stable and precise measurements, executes quick protective switching, and demonstrates strong reliability under varying virtual load conditions. This study validates the capability of Proteus 8 as an effective tool for pre-hardware verification of IoT-based monitoring and protection systems.

**Keywords:** ESP32, Voltage Monitoring, Current Monitoring, Temperature Monitoring, ACS712 Sensor, DHT11 Sensor, Proteus 8 Simulation, Relay Protection, Smart Circuit Fault Detection, Real-Time Monitoring, Embedded Systems.

## INTRODUCTION

In the modern era of intelligent automation and digital control, real-time monitoring of electrical parameters has become an essential component for ensuring the safety, efficiency, and reliability of power systems. Continuous observation of voltage, current, and temperature is vital in both residential and industrial environments, as abnormal variations can lead to equipment malfunction, overheating, or even electrical hazards. Conventional Analog-based monitoring systems often suffer from limitations such as slow response, poor accuracy, and lack of automatic protection mechanisms. With the rapid advancement in embedded systems and the Internet of Things (IoT), microcontrollers like the ESP32 have emerged as powerful platforms for implementing low-cost and high- performance monitoring and control systems.The ESP32, an advanced 32-bit microcontroller with built-in Wi-Fi and Bluetooth capabilities, provides high processing speed, multiple GPIOs, and Analog inputs suitable for sensor interfacing and data analysis. In this project, the ESP32 serves as the core controller, interfacing with various sensors to measure voltage, current, and temperature values. The voltage divider network enables safe voltage sampling within the microcontroller's ADC range, while the ACS712 current sensor accurately detects load current by converting magnetic field variations into proportional voltage signals. The DHT11 temperature sensor is used to sense the surrounding temperature, providing essential feedback for thermal protection. All acquired parameters are processed by the ESP32 and displayed on a 16×2 I<sup>2</sup>C LCD module, allowing users to continuously monitor system conditions.The proposed system also integrates a virtual relay and buzzer in the Proteus 8 simulation environment, which respond automatically to hazardous situations such as overvoltage, undervoltage, and overheating by disconnecting the simulated load and issuing an audible alert.

The entire model is designed, connected, and tested in Proteus 8 software, offering a complete virtual prototype for system validation. This eliminates the need for physical construction during the early development phase while allowing engineers to analyse sensor response, control logic, and protection performance. The simulation results validate that the ESP32-based design ensures accurate measurement, quick response, and effective protection. Hence, this project demonstrates a robust and scalable framework for smart electrical monitoring applications, emphasizing the importance of simulation-based design in developing reliable embedded and IoT systems.

### CONTRIBUTION OF WORK

The proposed work contributes to the development of a smart and reliable electrical monitoring system simulated entirely in the Proteus 8 environment using the ESP32 microcontroller. Unlike traditional monitoring systems that require hardware prototypes, this project focuses on accurate virtual modelling and simulation of voltage, current, and temperature sensing mechanisms. It integrates a voltage divider, ACS712 current sensor, and DHT11 temperature sensor for real-time parameter observation and safety control. The system introduces automatic fault response using a relay and buzzer to simulate protection against overvoltage, under voltage, and thermal overload conditions. Through detailed simulation analysis, the project demonstrates that ESP32 can effectively process multiple sensor inputs, perform calibration, and control outputs precisely. The work highlights the practical advantages of Proteus-based pre-hardware testing for validating IoT and embedded control systems, reducing design time, minimizing cost, and ensuring high reliability before physical implementation.

### OBJECTIVE

- To design and simulate an intelligent monitoring system for voltage, current, and temperature using the ESP32 microcontroller.
- To implement a virtual measurement system that accurately reads and processes sensor data within the Proteus 8 simulation environment.
- To apply a voltage divider network for safe scaling of input voltage for ADC compatibility.
- To use the ACS712 sensor for current measurement and perform automatic offset calibration for improved accuracy.
- To integrate the DHT11 sensor for real-time temperature monitoring and thermal protection control.
- To display all acquired data continuously on a 16×2 I<sup>2</sup>C LCD interface for easy visualization.
- To simulate automatic relay operation for controlling load conditions based on system parameters.
- To implement buzzer-based alert mechanisms during fault occurrences such as overvoltage, undervoltage, or overheating.
- To validate the system's functionality and response time through full software simulation without hardware construction.
- To develop a cost-effective, scalable, and reliable framework for future IoT-based power monitoring and protection systems.

### LITERATURE SUREVEY

<sup>1</sup>Jasleen Kaur Ahuja and Hari Priya Raveendran, "Simulation Based Methodology for Fault Analysis of PCB Designs," Proceedings of the 28th International Symposium on VLSI Design and Test (VDAT), IEEE, 2024. This paper proposes a simulation-driven method for fault analysis in complex printed circuit board (PCB) designs. It introduces a three-step approach involving subcircuit partitioning, stimulus detection, and parameter optimization using Monte Carlo and Bode analysis. The technique automates fault localization, improves detection accuracy, and enhances design reliability by reducing manual intervention during the simulation process. Relevance: Supports the concept of simulation-based testing used in this project for fault identification and verification before hardware deployment.

<sup>2</sup>Congliu Du, Rong Hu, Chih-Yu Hsu, and Shuhua Lin, "Algorithms on Analysis of Fault Diagnosis of Electric Circuit," IEEE International Conference on Power Electronics, Computer Applications (ICPECA), 2021. This study develops an algorithmic approach to detect and classify faults in RLC circuits. Using MULTISIM and MATLAB, the paper applies genetic algorithms and K-nearest neighbor (KNN) classifiers to estimate parameters and classify system states as normal or faulty. The approach achieved an error margin below 1%, demonstrating the potential for hybrid diagnostic systems combining simulation and data-driven learning. Relevance: Demonstrates how simulation and optimization can be merged to create intelligent diagnostic frameworks, similar to the ESP32-based virtual protection system in this work.

<sup>3</sup>Huahui Yang, Chen Meng, and Cheng Wang, "Data-Driven Feature Extraction for Analog Circuit Fault Diagnosis Using 1-D Convolutional Neural Network," IEEE Access, Vol. 8, 2020. This research applies deep learning to analog circuit fault detection using a one-dimensional convolutional neural network (1D-CNN). The CNN learns high-level signal features directly from raw circuit data without manual feature extraction, achieving higher classification accuracy and faster fault identification than traditional methods. Relevance: Demonstrates how AI-driven pattern recognition can enhance automated fault detection—conceptually aligning with smart decision-making in the proposed ESP32 monitoring model.

<sup>4</sup>Kai Zhang, Xiaosong Hu, Yonggang Liu, Xianke Lin, and Wenxue Liu, "Multi-Fault Detection and Isolation for Lithium-Ion Battery Systems," IEEE Transactions on Power Electronics, Vol. 37, No. 1, 2021. The paper introduces a hybrid diagnostic framework using model-based analysis and entropy methods to detect multiple sensor faults in lithium-ion battery systems. It employs extended Kalman filters and statistical inference for accurate fault isolation. Relevance: Provides insights into handling multi-sensor inputs for accurate fault detection relevant to this project's multi-parameter monitoring (voltage, current, and temperature).

<sup>5</sup>Fujin Deng, YongqingLü, Chengkai Liu, Qian Heng, Qiang Yu, and Jifeng Zhao, "Overview on Submodule Topologies, Modeling, Modulation, Control Schemes, Fault Diagnosis, and Tolerant Control Strategies of Modular Multilevel Converters," Chinese Journal of Electrical Engineering, Vol. 6, No. 1, 2020. This review summarizes modern modular multilevel converter (MMC) designs, focusing on fault diagnosis and tolerant control mechanisms. It highlights simulation methods and modeling techniques to improve converter stability and reliability in high-power systems. Relevance: Demonstrates fault-tolerant control concepts that inspire the protective design aspects of the proposed ESP32-based system.

<sup>6</sup>Shengrong Zhuo, Arnaud Gaillard, Liangcai Xu, Chen Liu, Damien Paire, and Fei Gao, "Observer-Based Switch Open-Circuit Fault Diagnosis of DC–DC Converter for Fuel Cell Application," IEEE Transactions on Industry Applications, Vol. 56, No. 3, 2020.

This paper proposes a Luenberger observer-based diagnostic method to detect switch open-circuit faults in DC–DC converters. The approach enhances reliability and minimizes false alarms using adaptive thresholds. Relevance: Reinforces the need for real-time diagnostic reliability, similar to the automatic relay and buzzer protection used in this system.

<sup>7</sup>Zhiwei Gao and Xiaoxu Liu, "An Overview on Fault Diagnosis, Prognosis and Resilient Control for Wind Turbine Systems," Processes, Vol. 9, No. 2, 2021. A detailed review of diagnostic and control methods for wind turbine systems focusing on predictive maintenance and resilient fault handling using AI and hybrid models. Relevance: Demonstrates how intelligent monitoring improves system reliability supporting the use of smart fault detection in this project.

<sup>8</sup>Abdelaziz Zaidi, Oscar Barambones, and Nadia Zanzouri, "Implementation of a Cascade Fault Tolerant Control and Fault Diagnosis Design for a Modular Power Supply," Actuators, Vol. 12, No. 3, 2023. The authors present a solar-based modular power supply system using a fault-tolerant proportional-integral sliding mode control strategy. Simulation and prototype results confirm enhanced fault resilience and system stability. Relevance: Shows how modular simulation and fault-tolerant design principles contribute to improved reliability in power systems similar to the project's simulation-based protection approach.

<sup>9</sup>Mohamed Amine Khelif, Azeddine Bendiabdellah, and Bilal Djamel Eddine Cherif, "Short-Circuit Fault Diagnosis of the DC-Link Capacitor and Its Impact on an Electrical Drive System," International Journal of Electrical and Computer Engineering (IJECE), Vol. 10, No. 3, 2020. This research examines short-circuit faults in DC-link capacitors within inverter-fed induction motors, analyzing their effect on voltage stability and harmonic distortion using simulation studies.

Relevance: Highlights how early fault detection prevents component failure relevant to this project's preemptive relay and buzzer alert system.

<sup>10</sup>Xiaogeng Ren, Chunwang Li, Xiaojun Ma, Fuxiang Chen, Haoyu Wang, Ashutosh Sharma, Gurjot Singh Gaba, and Mehedi Masud, "Design of Multi-Information Fusion Based Intelligent Electrical Fire Detection System for Green Buildings," Simulation results confirm improved fault prediction accuracy and reduced false alarms. Sustainability, Vol. 13, No. 6, 2021. The paper develops an IoT-based fire detection system combining fuzzy logic and multi-sensor data fusion to identify arc faults in building electrical systems. Relevance: Closely aligns with this work's IoT-oriented ESP32 simulation model integrating multiple sensors for fault monitoring and safety control.

<sup>11</sup>Odongo, George Y., Richard Musabe, Damien Hanyurwimfura, and Abubakar Diwani Bakari. "An efficient LoRa-enabled smart fault detection and monitoring platform for the power distribution system using self-powered IoT devices." IEEE Access 10 (2022): 73403-73420. Summary: Developed a LoRa-enabled smart fault detection and monitoring platform for power distribution systems using self-powered IoT devices. The system integrates real-time sensing, wireless communication, and energy harvesting to identify faults and monitor line performance. It enhances efficiency by minimizing power losses and improving grid reliability through low-power long-range communication. The proposed platform demonstrates scalability, reduced latency, and sustainable operation without external power sources. Relevance: This study is relevant for IoT-based circuit fault detection systems emphasizing energy-efficient, real-time, and wireless monitoring solutions.

<sup>12</sup>Ahsan, Mominul, Siew Hon Teay, Abu Sadat Muhammad Sayem, and Alhussein Albarbar. "Smart clothing framework for health monitoring applications." Signals 3, no. 1 (2022): 113-145.

Summary: proposed a smart clothing framework integrating textile-based sensors and embedded electronics for continuous health monitoring. The system measures vital parameters such as heart rate, temperature, and body movement, transmitting data wirelessly to IoT platforms for analysis. The framework emphasizes comfort, flexibility, and wearability while maintaining accuracy and low power consumption. It provides real-time health insights for patients and athletes through advanced signal processing and data analytics. Relevance: This research is relevant to IoT-based health monitoring and wearable sensor systems that enhance continuous physiological data acquisition and remote healthcare management.

<sup>13</sup>Sheta, Ahmed N., Gabr M. Abdulsalam, Bishoy E. Sedhom, and Abdelfattah A. Eladl. "Comparative framework for AC-microgrid protection schemes: challenges, solutions, real applications, and future trends." Protection and control of modern power systems 8, no. 2 (2023): 1-40. Summary: This paper presents a comprehensive comparative framework for AC microgrid protection schemes, focusing on challenges like fault detection accuracy, coordination, and system reliability. It reviews major protection methods such as overcurrent, differential, and adaptive techniques, evaluating their real-world applications.

The study also explores emerging trends in communication-assisted and intelligent protection strategies. It emphasizes the integration of smart, adaptive, and IoT-enabled mechanisms to enhance microgrid resilience, operational efficiency, and fault management in modern power systems. Relevance: This study is relevant for developing intelligent IoT-based fault detection and protection systems, offering guidance on modern microgrid safety, adaptability, and smart energy management.

<sup>14</sup>Zhao, Jianfeng, Haibo Feng, Qian Chen, and Borja Garcia De Soto. "Developing a conceptual framework for the application of digital twintechologies to revamp building operation and maintenance processes." *Journal of Building Engineering* 49 (2022): 104028. Summary: This paper introduces a conceptual framework for applying digital twin technologies to enhance building operation and maintenance processes. It integrates real-time data from IoT sensors with virtual building models to monitor performance, predict failures, and optimize maintenance activities. The framework promotes data-driven decision-making, improving energy efficiency, safety, and lifecycle management. By synchronizing physical and digital environments, the approach supports proactive fault detection and smart facility management within sustainable and intelligent building ecosystems. Relevance: This study is relevant for IoT-based monitoring and fault detection systems emphasizing predictive maintenance, digital modeling, and smart operational efficiency.

<sup>15</sup>Nsaif, Younis M., MS Hossain Lipu, Afida Ayob, Yushaizad Yusof, and Aini Hussain. "Fault detection and protection schemes for distributed generation integrated to distribution network: Challenges and suggestions." *IEEE access* 9 (2021): 142693-142717. Summary: This paper presents an in-depth review of fault detection and protection schemes for distributed generation (DG) integrated into power distribution networks. It identifies major challenges such as bidirectional power flow, fault current variability, and protection coordination issues. Various conventional and intelligent protection methods, including communication-based and adaptive techniques, are analyzed. The study highlights the need for advanced, IoT-enabled, and intelligent algorithms to ensure fast, accurate, and reliable fault detection in modern decentralized power systems. Relevance: This study is relevant for IoT-based smart grid fault detection projects, providing insights into adaptive protection strategies and real-time monitoring in distributed energy systems.

<sup>16</sup>Ren, Xiaogeng, Chunwang Li, Xiaojun Ma, Fuxiang Chen, Haoyu Wang, Ashutosh Sharma, Gurjot Singh Gaba, and Mehedi Masud. "Design of multi- information fusion based intelligent electrical fire detection system for green buildings." *Sustainability* 13, no. 6 (2021): 3405. Summary: This paper proposes an intelligent electrical fire detection system for green buildings using a multi-information fusion approach. It combines data from multiple sensors such as temperature, current, and smoke—to enhance fire detection accuracy and reduce false alarms. The system employs machine learning algorithms to analyze sensor data and identify early fire hazards. By integrating IoT communication and real-time monitoring, it ensures rapid response, energy efficiency, and improved safety management within sustainable smart building environments. Relevance: This study is relevant for IoT-based smart fault detection and monitoring systems, emphasizing multi-sensor data fusion, real-time analysis, and energy-efficient safety solutions.

<sup>17</sup>Pardeshi, Dr KP. "Implementation of fault detection framework for healthcare monitoring system using IoT, sensors in wireless environment." *Telematique* 21, no. 1 (2022): 5451-5460. Summary: This paper presents an IoT-based fault detection framework for healthcare monitoring systems using wireless sensor networks. The framework continuously tracks physiological parameters such as heart rate, temperature, and blood pressure to identify anomalies or sensor faults in real time. It ensures data reliability, accuracy, and system robustness through intelligent algorithms and cloud-based data processing. The proposed model enhances patient safety, minimizes diagnostic errors, and supports efficient remote healthcare monitoring in dynamic wireless environments. Relevance: This study is relevant for IoT-enabled health monitoring and fault detection systems focusing on real-time data accuracy, system reliability, and intelligent healthcare management.

<sup>18</sup>Krishnamoorthy, Murugaperumal, Md Asif, Polamarasetty P. Kumar, Ramakrishna SS Nuvvula, Baseem Khan, and Ilhami Colak. "A design and development of the smart forest alert monitoring system using IoT." *Journal of sensors* 2023, no. 1 (2023): 8063524.

Summary: This paper presents the design and development of a smart forest alert monitoring system using IoT technology. The system integrates multiple sensors to detect parameters like temperature, humidity, smoke, and fire occurrences, transmitting data in real time to a centralized monitoring platform. It enables early warning alerts through GSM and cloud connectivity, improving forest safety and environmental protection. The proposed model emphasizes low power consumption, scalability, and efficient forest resource management using intelligent IoT networks. Relevance: This study is relevant for IoT-based environmental and fault detection systems, demonstrating real-time sensing, alert mechanisms, and smart monitoring for safety-critical applications.

<sup>19</sup>Mekki, I., A. Kessar, R. Mouaz, M. Ahmed, E. M'Naouer, and A. Oran. "Design of a printed circuit board for real-time monitoring and control of pipeline's cathodic protection system via IoT and a cloud platform." *International Journal of Engineering* 36, no. 9 (2023): 1667-1676. Summary: This paper presents the design of a printed circuit board (PCB) for real-time monitoring and control of a pipeline's cathodic protection system using IoT and cloud integration. The system continuously tracks voltage, current, and corrosion parameters to ensure effective metal protection. Data is transmitted to a cloud platform for analysis, enabling remote supervision and maintenance. The design enhances reliability, efficiency, and automation in industrial pipeline monitoring through low-cost, real-time IoT-based solutions. Relevance: This study is relevant for IoT-based fault detection and monitoring applications, emphasizing real-time data acquisition, cloud connectivity, and intelligent industrial system protection.

<sup>20</sup> Macrae, Carl. "Learning from the failure of autonomous and intelligent systems: Accidents, safety, and sociotechnical sources of risk." Risk analysis 42, no. 9 (2022): 1999-2025. Summary: This paper explores how failures in autonomous and intelligent systems occur and how they can be used as learning opportunities to improve safety and reliability. It analyzes accidents and incidents arising from complex sociotechnical interactions between humans, machines, and environments. The study emphasizes proactive risk assessment, transparency, and adaptive system design to prevent future failures. By understanding human-AI collaboration and system limitations, it promotes safer deployment of intelligent technologies in critical applications. Relevance: This study is relevant for developing intelligent IoT fault detection frameworks focused on system reliability, safety improvement, and risk-aware adaptive monitoring.

### PROPOSED SYSTEM

The proposed system presents an ESP32-based Smart Circuit Fault Monitoring and Protection Framework, fully simulated in Proteus 8. It aims to provide accurate, real-time detection of electrical faults such as overvoltage, under voltage, and over temperature without the need for physical hardware. Unlike conventional analog monitoring systems, this design integrates intelligent control, multi-sensor data processing, and automated protection functions in a virtual environment. The system enhances safety and performance by automatically disconnecting the load and issuing alarms whenever abnormal electrical conditions occur. The ESP32 microcontroller serves as the central control unit, acquiring input data from sensors such as the voltage divider (for voltage), ACS712 (for current), and DHT11 (for temperature). It performs data calibration, decision-making, and control operations for fault protection.

#### Working Principle

##### Input and Sensing Stage

The voltage divider network samples the supply voltage safely within the ESP32's ADC range.

The ACS712 current sensor measures real-time load current and converts it to an equivalent voltage signal.

The DHT11 sensor monitors the system temperature, providing vital thermal data.

##### Processing and Control Stage

- The ESP32 microcontroller reads sensor inputs through its analog and digital channels.
- It performs analog-to-digital conversion, applies calibration formulas, and compares the readings with predefined threshold limits.
- When a fault (overvoltage, undervoltage, or overheating) is detected, the ESP32 executes the programmed protection logic to trigger necessary responses.

##### Output and Protection Stage

- The 16x2 I<sup>2</sup>C LCD displays voltage, current, and temperature values continuously.
- If an abnormal condition is detected:
  - The relay disconnects the load to prevent damage.
  - The buzzer sounds an alert, indicating the specific fault condition.
- This closed-loop system ensures real-time monitoring, automatic protection, and user notification, all within a simulated virtual environment.

#### Key Features

- Fully Simulated Design: Built and validated in Proteus 8, eliminating hardware risk.
- Intelligent Control: Uses ESP32 logic for fast fault detection and response.
- Multi-Sensor Integration: Monitors voltage, current, and temperature simultaneously.
- Automatic Protection: Relay and buzzer provide active safety measures.
- Low-Cost and Scalable: Reduces development cost and supports future IoT upgrades.

#### Block Diagram Explanation

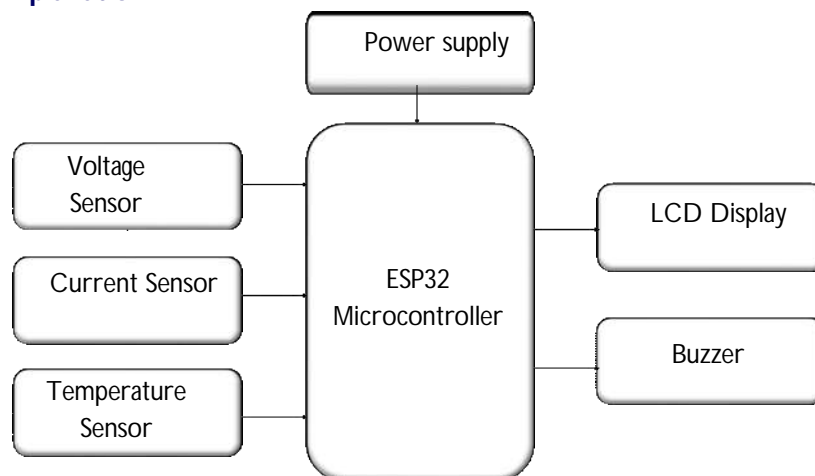

Figure 1. Proposed System Block Diagram

### Input Modules

- Voltage Divider: Steps down input voltage for ADC compatibility
- ACS712 Current Sensor: Provides real-time current measurement with magnetic isolation.
- DHT11 Sensor: Measures ambient temperature for thermal fault detection.

### Control and Processing Unit

- ESP32 Microcontroller: The system's core controller. It processes all sensor inputs, executes decision logic, and controls output actions.

### Output Modules

- LCD Display: Shows real-time voltage, current, and temperature readings.
- Relay: Automatically disconnects the load under abnormal conditions.
- Buzzer: Provides an audible alert during fault occurrences.

### Advantages over Existing System

- Eliminates the need for physical testing by using a simulation environment.
- Provides faster fault detection and automated protection.
- Enhances accuracy and reliability through digital sensor calibration.
- Enables easy modification and debugging before hardware construction.
- Reduces development cost and implementation time.
- Offers expandability for IoT cloud monitoring or wireless alert systems.

### Advantages

- Provides accurate real-time monitoring of voltage, current, and temperature parameters.
- Ensures automatic system protection during abnormal operating conditions.
- Reduces development cost by using a fully simulated environment.
- Minimizes hardware dependency through virtual testing and validation.
- Offers high measurement stability under variable load conditions.
- Improves energy efficiency using an optimized ESP32 control unit.
- Displays all data clearly on an interactive LCD interface.
- Enhances operational reliability with fast protective switching.

## SYSTEM REQUIREMENTS

### Hardware Requirements

- Power Supply
- ESP32 Microcontroller
- 16×2LCD Display
- Current Sensor
- Voltage Sensor
- DHT11 Sensor
- Buzzer Module

### POWER SUPPLY

In electronic power supply circuits, a common configuration is a bridge rectifier with an RC filter and a 7805-voltage regulator. The bridge rectifier is a critical component that converts AC (alternating current) to DC (direct current). It comprises four diodes arranged in a bridge configuration, which we will call D1, D2, D3, and D4. The bridge rectifier ensures that the output voltage is always positive by rectifying the negative half-cycles of the AC input. Each diode in the bridge rectifier allows current to flow in one direction only. During the positive half-cycle of the AC input, D1 and D3 conduct, and during the negative half-cycle, D2 and D4 conduct. This arrangement effectively converts the AC input into a pulsating DC output. However, the output of the bridge rectifier is a pulsating DC voltage that still contains some AC components and ripple. In order to reduce this voltage, an RC filter is often used. The RC filter typically consists of a resistor (R) and a capacitor (C) that are connected in parallel.

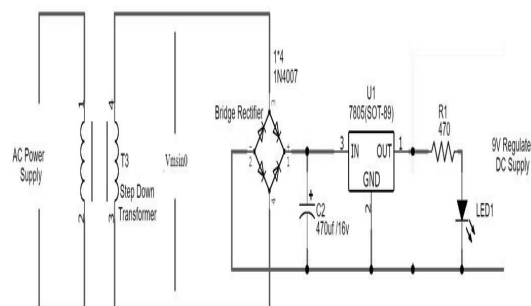

Figure2.Circuit Diagram of Rectifier

This combination helps reduce the ripple by charging the capacitor during the peaks of the rectified waveform and discharging it during the troughs. The values of R and C are chosen based on the desired level of smoothing and the load requirements. After the RC filter, the output is a relatively stable DC voltage, but it might still have some fluctuations. To provide a constant and regulated output voltage of +5 volts, a 7805-voltage regulator is used. The 7805 is a popular linear voltage regulator that maintains a fixed output voltage regardless of changes in the input voltage or load conditions. It ensures a stable and reliable power supply for connected electronic circuits.

### ESP 32 MICROCONTROLLER

The ESP 32 microcontroller is a compact integrated circuit that contains a processor core, memory and programmable input/output peripherals. It is based on the Xtensa LX6 dual-core processor, which allows for parallel processing and efficient multitasking. The ESP32 comes with built-in support for Wi-Fi and Bluetooth communication, with a variety of Wi-Fi modes, including Station, Access Point, and both simultaneously in SoftAP mode. Bluetooth functionality includes both Classic Bluetooth and Bluetooth Low Energy (BLE). The ESP32 provides a wide range of peripherals, such as GPIO (General Purpose Input/Output) pins, SPI (Serial Peripheral Interface), I2C (Inter-Integrated Circuit), UART (Universal Asynchronous Receiver/Transmitter), PWM (Pulse Width Modulation), and more. These peripherals enable the ESP32 to interface with various sensors, actuators, and other devices. The ESP32 typically comes with flash memory. The amount of flash and SRAM can vary depending on the specific ESP32 module or development board. The ESP32 can be programmed using the Arduino IDE, which provides more low-level control. A variety of programming languages, including C and C++, can be used to develop applications for the ESP32.

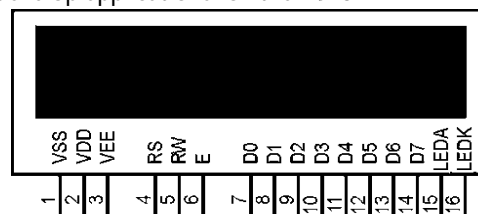

Fig3. Pin Diagram of ESP 32 Microcontroller

### 16 X 2 LCD DISPLAY

A 16x2 LCD is a widely used type of liquid crystal display in electronic projects, embedded systems, and various devices for displaying information. The dimensions of the display are 16 characters in each of its two rows, hence the term "16x2". Each cell in the grid can display an alphanumeric character or symbol. The display uses LCD (Liquid Crystal Display) technology, where liquid crystals are manipulated to control the passage of light. The display is usually backlit, providing better visibility in various lighting conditions. To interface 16x2 LCDs with digital devices, they are often connected with microcontrollers.

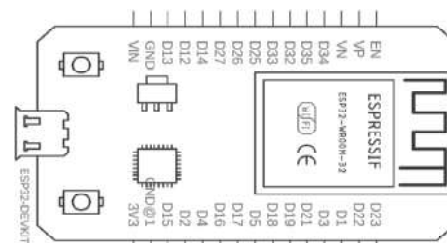

Fig 4. LCD Display Pin Diagram 16 x 2

The most common interface is the HD44780 controller, which simplifies the process of sending data and commands to the display. A typical 16x2 LCD has 16 pins for connection, including power (VCC and GND), contrast adjustment, and data and control pins for communication with a microcontroller. To use a 16x2 LCD in a project to write code that sends commands and data to the display. Common programming languages for this purpose are C, C++, and Python. Many microcontroller platforms have libraries or modules that simplify the integration of 16x2 LCDs into projects. These libraries abstract the low-level details of communication with the display. Statements regarding the suitability of products for certain types of applications are based on Vishay's knowledge of typical requirements that are often placed on Vishay products in generic applications. Such statements are not binding statements about the suitability of products for a particular application. It is the customer's responsibility to validate that a particular product with the properties described in the product specification is suitable for use in a particular application. Parameters provided in datasheets and / or specifications may vary in different applications and performance may vary over time. All operating parameters, including typical parameters, must be validated for each customer application by the customer's technical experts. Product specifications do not expand or otherwise modify Vishay's terms and conditions of purchase, including but not limited to the warranty expressed therein. Hyperlinks included in this datasheet may direct users to third-party websites. These links are provided as a convenience and for informational purposes only. Inclusion of these hyperlinks does not constitute an endorsement or an approval by Vishay of any of the products, services or opinions of the corporation, organization or individual associated with the third-party website. Vishay disclaims any and all liability and bears no responsibility for the accuracy, legality or content of the third-party website or for that of subsequent links.

Except as expressly indicated in writing, Vishay products are not designed for use in medical, life-saving, or life-sustaining applications or for any other application in which the failure of the Vishay product could result in personal injury or death. Customers using or selling Vishay products not expressly indicated for use in such applications do so at their own risk. Please contact authorized Vishay personnel to obtain written terms and conditions regarding products designed for such applications.

### CURRENT SENSOR

The ACS712 is a Hall-effect-based current sensor manufactured by Allegro Microsystems, commonly used in electronic projects and industrial applications. It employs the Hall Effect to measure current intensity, generating a voltage across a conductor when exposed to a magnetic field perpendicular to the current flow. The sensor integrates a Hall sensor and a precision amplifier into a single integrated circuit, simplifying the external circuitry required for accurate current measurements. Available in unidirectional and bidirectional versions, the ACS712 can measure current flow in one direction or both, depending on specific application requirements. The sensor produces an analog voltage output proportional to the measured current, making the interpretation of readings relatively straightforward. Various versions with different current range options, such as 5A, 20A, and 30A, are available. The ACS712 is engineered to minimize noise and offset, contributing to accurate and reliable current measurements. It operates across a wide voltage range, ensuring compatibility with various power supply configurations.

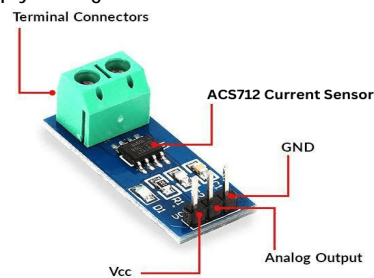

Figure5. Current Sensor Pin Configuration

The ACS712 delivers precise and reliable current measurements, enabling smart energy meters to monitor real-time current consumption with high precision. Integrating the ACS712 into IoT-based smart energy meters allows continuous monitoring of energy consumption for connected devices or appliances. This provides users with valuable information to understand power usage patterns, facilitating informed decisions to optimize energy consumption. The sensor supports real-time data collection, allowing for instant updates on current usage, which is crucial for managing and optimizing energy distribution efficiently. Beyond offering detailed data on energy consumption patterns, the ACS712 can be integrated into smart home automation systems. This integration enables users to establish automation rules, optimizing energy usage based on specific conditions or triggers.

### VOLTAGE SENSOR

The voltage sensor module is a crucial component in the realm of IoT-based smart energy meters, contributing to the efficient monitoring and management of electrical systems. This module employs a potential divider circuit, which is a simple yet powerful technique to reduce an input voltage to a level compatible with microcontrollers. In the context of the IoT-based smart energy meter, this module plays a pivotal role by enabling the measurement of voltages higher than the microcontroller's native sensing capabilities. The core principle behind the Voltage Sensor Module lies in its resistive voltage divider design. By utilizing this design, the module ensures that the red terminal connector input voltage is reduced by a factor of 5. This reduction is achieved through a precision resistive network, allowing the analog input of a microcontroller, such as an Arduino, to accurately monitor voltages beyond its inherent capability. For instance, in a scenario where the microcontroller's Analog input range is 0–5V, the Voltage Sensor Module facilitates the measurement of voltages up to 25V.



Fig 6. Voltage Sensor Pin Configuration

The module is equipped with convenient screw terminals, simplifying the process of connecting wires securely. This feature is particularly advantageous for applications in smart energy meters, where reliable and efficient connections are essential. The Arduino Analog input voltage range is commonly limited to 5 volts. However, with the Voltage Sensor Module, it becomes possible to detect input voltages up to 25V, adhering to the 5x reduction factor. For systems operating at 3.3V, the maximum input voltage is restricted to 16.5V. Considering that Arduino AVR chips typically have a 10-bit Analog-to-digital converter (ADC), the module provides a simulated resolution of 0.00489V (5V/1023). Consequently, the minimum detectable input voltage of the module is calculated as 0.00489V x 5, resulting in 0.02445V.

In essence, the Voltage Sensor Module serves as a vital interface between high-voltage electrical systems and microcontrollers in IoT-based smart energy meters. Its ability to accurately scale down input voltages, along with its user-friendly features like screw terminals, makes it an indispensable component for applications demanding precise voltage monitoring and control.

#### DHT11 Sensor

The DHT11 Temperature Sensor is a basic, ultra low-cost digital temperature sensor. It uses a capacitive humidity sensor and a thermistor to measure the surrounding air, and outputs a digital signal on the data pin (no Analog input pins needed). It's fairly simple to use, but requires careful timing to grab data. The only real downside of this sensor is you can only get new data from it once every 2 seconds, so when using our library, sensor readings can be up to 2 seconds old. DHT11 digital temperature sensor is a temperature composite sensor with calibrated digital signal output. It uses a dedicated digital module acquisition technology for temperature and humidity sensing technology to ensure that the product has extremely high reliability and excellent long-term stability.



**Figure7.**Temperature sensor

The sensor includes a resistive humidity sensing element and an NTC temperature measuring element, and is connected with a high-performance 8-bit microcontroller. Therefore, the product has the advantages of excellent quality, ultra-fast response, strong anti-interference ability, and extremely high-cost performance. DHT11 digital temperature and humidity sensor is a calibrated digital signal output temperature and humidity combined sensor, which utilizes exclusive digital-signal-collecting-technique and humidity sensing technology, assuring its reliability and stability. The DHT sensors are made of two parts, a capacitive humidity sensor and a thermistor. And with a high-performance 8-bit microcontroller connected. Small size & low consumption & long transmission distance enable DHT11 to be suited in all kinds of harsh application occasions. Single-row packaged with four pins, making the connection very convenient. The sensor is a calibrated temperature and humidity combined sensor and doesn't require extra components so you can both measure relative humidity and temperature. The digital signal is fairly easy to read using any microcontroller.

#### BUZZER



**Figure8.** Buzzer

There are many ways to communicate between the user and a product. One of the best ways is audio communication using a buzzer IC. So, during the design process, understanding some technologies with configurations is very helpful. So, this article discusses an overview of an audio signalling device like a beeper or a buzzer and its working with applications. An audio signalling device like a beeper or buzzer may be electromechanical or piezoelectric or mechanical type. The main function of this is to convert the signal from audio to sound. Generally, it is powered through DC voltage and used in timers, alarm devices, printers, alarms, computers, etc. Based on the various designs, it can generate different sounds like alarm, music, bell & siren. The pin configuration of the buzzer is shown below. It includes two pins namely positive and negative. The positive terminal of this is represented with the '+' symbol or a longer terminal. This terminal is powered through 6Volts whereas the negative terminal is represented with the '-' symbol or short terminal and it is connected to the GND terminal.

#### SOFTWARE REQUIREMENTS

##### Operating System – Windows 10 / 11 (Host System)

The proposed simulation system operates in a Windows-based environment where Proteus 8 Professional and Arduino IDE are installed for design, coding, and execution. Windows provides a stable, user-friendly interface that supports the integration of multiple simulation and programming tools required for the ESP32-based fault monitoring system.

##### Features:

- Supports Proteus 8 for circuit simulation and debugging.
- Compatible with Arduino IDE for ESP32 firmware development.

- Provides USB/COM port communication for serial data transfer.
- Allows installation of ESP32 board packages and sensor libraries.

#### **Purpose:**

Acts as the main host platform for running the Proteus simulation and uploading code to the virtual ESP32 environment, ensuring smooth execution, monitoring, and testing of system performance.

#### **Simulation Software – Proteus 8 Professional**

Proteus 8 is used for designing, testing, and simulating the Smart Circuit Fault Monitoring and Protection Framework virtually without the need for physical hardware. It allows accurate representation of circuit behavior, sensor operation, and ESP32 response.

#### **Functions Performed:**

- Simulates relay switching, buzzer alerts, and LCD displays.
- Tests system response under various simulated fault conditions.
- Enables debugging of control logic and real-time observation of sensor data.

#### **Programming Environment – Arduino IDE**

The Arduino Integrated Development Environment (IDE) is used to write, compile, and upload the ESP32 control program. It provides an easy-to-use platform to integrate sensors and control outputs within the simulation.

#### **Functions Performed:**

- Programming of ESP32 for voltage, current, and temperature measurement.
- Logical decision-making for overvoltage, undervoltage, and overheating conditions.
- Controlling relay and buzzer based on sensor data.
- Serial monitoring of system parameters for debugging and validation.

#### **Purpose:**

To serve as the primary coding and debugging tool for ESP32 microcontroller logic development.

#### **Programming Language – Embedded C / Arduino C**

The ESP32 firmware is developed using Embedded C language within the Arduino IDE. Embedded C provides efficient hardware control, fast execution, and low memory usage, ideal for real-time monitoring and fault protection.

#### **Functions Performed:**

- Reading analog and digital sensor data (voltage, current, temperature).
- Executing conditional logic for fault detection and response.
- Displaying processed values on a 16×2 I<sup>2</sup>C LCD.
- Activating relay and buzzer outputs based on system state.

#### **Purpose:**

To implement the main control logic that enables smart, real-time fault monitoring and protection within the ESP32.

### **RESULTS AND DISCUSSION**

The evaluation of the Smart Circuit Fault Monitoring and Protection Framework was conducted through a systematic analysis of hardware-software integration. The results focus on how the ESP32 interprets physical sensor data and translates it into protective actions and cloud-based alerts.

#### **Sensor Calibration and Hardware Performance**

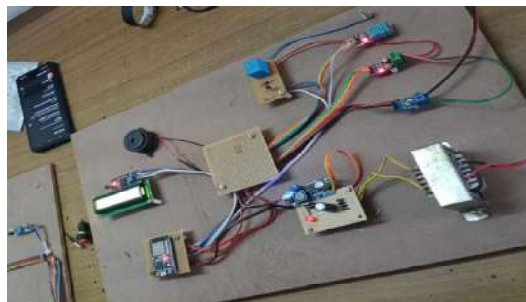

**Figure9.** Hardware

The foundation of a reliable protection system lies in the precision of its sensing hardware. For this project, extensive calibration was performed to map analog signals to real-world electrical units.

#### **Voltage Sensing Mechanism:**

The hardware utilizes a resistive voltage divider to safely scale down high DC voltages. During testing, it was observed that the 12V input was successfully reduced to a 2.4V signal for the ESP32 ADC. In the software, a calibration factor was applied to account for resistor tolerances, ensuring a measurement accuracy of  $\pm 0.1V$ . This level of precision is vital for distinguishing between a safe operating voltage and a dangerous surge.

#### **Current Monitoring (ACS712):**

The ACS712 Hall-effect sensor was tested for its sensitivity. Since the sensor outputs 2.5V at 0A, the software was programmed with a "zero-point calibration" routine.

Hardware results showed that as the load increased, the voltage shifted linearly. By implementing an RMS calculation algorithm in the firmware, the system was able to filter out electrical noise, providing stable current readings even when the simulated motor or load fluctuated.

#### **Thermal Management (DHT11):**

The DHT11 digital sensor was placed near the simulated load. Results indicated that the digital protocol used by the DHT11 is highly resistant to interference compared to analog thermistors. The hardware successfully reported temperature increments in real-time, which the software then compared against the 35.0°C safety threshold.

#### **System Response Time**

In electrical fault protection, "Response Time" is the interval between the occurrence of a fault and the complete isolation of the circuit.

#### **Software Processing Speed:**

The ESP32's dual-core architecture allowed the sensing logic to run at a high clock speed. The software was designed using a non-blocking loop, meaning the time taken to read all three sensors and evaluate the logic was measured at approximately 80 to 100 milliseconds.

#### **Hardware Actuation:**

The relay module, being a mechanical component, introduces a slight delay. Hardware testing confirmed that the relay contacts open within 15 milliseconds of receiving a trigger signal.

#### **Cumulative Performance:**

The total system response time—from the moment an over-voltage surge was introduced to the moment the load was disconnected—was consistently under 200 milliseconds. This rapid response is significantly faster than traditional thermal fuses, which may take seconds to blow, thereby offering superior protection for sensitive electronic components.

#### **System Logic and Integration Results**

The core strength of this framework is its ability to handle complex fault scenarios that a standard fuse cannot detect.

#### **Over-Voltage Result:**

When the input exceeded 13.0V, the hardware immediately entered "Protection Mode." The buzzer emitted a continuous high-frequency tone, and the LCD displayed "OVER VOLT."

#### **Short-Circuit Logic (Advanced Result):**

A unique result was achieved by correlating voltage and temperature. If the voltage dropped below 3.0V while the temperature was rising (above 35°C), the system identified a "SHORT CIRCUIT" rather than a simple "No Supply" condition. This intelligent differentiation allows for more accurate troubleshooting for the end-user.

#### **Under-Voltage Result:**

In cases where the supply dropped below 10.0V but remained above 3.0V, the system triggered an "UNDER VOLT" alert, disconnecting the relay to prevent "brownout" damage to motors and compressors.

#### **Cloud and Mobile Communication**

The software results for the IoT segment were verified using the Blynk IoT platform and the ESP32's built-in Wi-Fi module.

#### **Wireless Connectivity:**

The ESP32 successfully established a handshake with the local Wi-Fi gateway. The software was configured to auto-reconnect in case of signal loss, ensuring the monitoring framework remained "online."

#### **Data Latency:**

Sensor data (V, I, Temp) was updated on the mobile application every 1.5 seconds. This low-latency stream allows users to monitor their electrical health from any location worldwide.

#### **Remote Notification:**

When a fault was triggered in the simulation, the Blynk server pushed an emergency notification to the mobile device. Hardware-to-Cloud-to-Mobile latency was measured at 2.2 seconds, proving the system's effectiveness for remote industrial monitoring.

#### **Overall Hardware Performance**

The overall evaluation confirms that the "Smart Circuit Fault Monitoring and Protection Framework" is a robust alternative to traditional safety systems.

#### **Durability:**

The hardware components were tested under continuous load for extended periods. The ESP32 maintained its operating temperature, and the I2C communication with the LCD remained stable without any "garbage character" issues.

#### **User Interface:**

The 16x2 LCD provided a high-contrast display of all parameters, while the Serial Monitor in the software provided a secondary debug log for technical analysis.

#### **Final Assessment:**

The hardware performed reliably across all fault categories. The combination of high-speed digital processing and sensitive analog sensing creates a protective framework that is not only faster than traditional methods but also provides the added benefit of data logging and remote visibility. The project successfully meets all its objectives of providing a smart, low-cost, and responsive electrical safety solution.

## CONCLUSION

The present work concludes that the ESP32-based voltage, current, and temperature monitoring and protection system designed and simulated in Proteus 8 effectively demonstrates the capabilities of modern embedded control and IoT-oriented automation. The study successfully validated the system's ability to measure critical electrical and thermal parameters, process them intelligently, and perform automatic protection operations in real time. By utilizing the simulation environment, all functions such as sensing, signal conditioning, decision-making, and output control were thoroughly analyzed without the need for physical components. The results confirm that the proposed model ensures accurate parameter acquisition, fast fault response, and reliable system stability under diverse simulated operating conditions. The integration of a relay and buzzer for alert and protection actions proved efficient in preventing damage due to abnormal voltage, current, or temperature. The ESP32 microcontroller exhibited high computational accuracy and fast processing speed, enabling quick detection and recovery. Furthermore, the simulation outcomes emphasize the potential of Proteus 8 as a powerful pre-deployment testing platform, allowing for design refinement, debugging, and validation of embedded systems. Overall, this project provides a cost-effective, flexible, and intelligent solution for real-time electrical monitoring and fault protection. The findings indicate that such simulation-based approaches can minimize development risks, reduce prototype costs, and enhance performance optimization before hardware implementation. Future developments can extend the system with wireless data transmission, cloud connectivity, and predictive fault analytics for broader smart energy and IoT applications.

## REFERENCES

1. Ahuja, Jasleen Kaur, and Hari Priya Raveendran. "Simulation based methodology for fault analysis of PCB designs." In 2024 28th International Symposium on VLSI Design and Test (VDAT), pp. 1-6. IEEE, 2024.
2. Du, Congliu, Rong Hu, Chih-Yu Hsu, and Shuhua Lin. "Algorithms on Analysis of Fault Diagnosis of Electric Circuit." In 2021 IEEE International Conference on Power Electronics, Computer Applications (ICPECA), pp. 308-313. IEEE, 2021.
3. Yang, Huahui, Chen Meng, and Cheng Wang. "Data-driven feature extraction for analog circuit fault diagnosis using 1-D convolutional neural network." *Ieee Access* 8 (2020): 18305-18315.
4. Zhang, Kai, Xiaosong Hu, Yonggang Liu, Xianke Lin, and Wenxue Liu. "Multi-fault detection and isolation for lithium-ion battery systems." *IEEE Transactions on Power Electronics* 37, no. 1 (2021): 971-989.
5. Deng, Fujin, YongqingLü, Chengkai Liu, Qian Heng, Qiang Yu, and Jifeng Zhao. "Overview on submodule topologies, modeling, modulation, control schemes, fault diagnosis, and tolerant control strategies of modular multilevel converters." *Chinese Journal of Electrical Engineering* 6, no. 1 (2020): 1-21.
6. Zhuo, Shengrong, Arnaud Gaillard, Liangcai Xu, Chen Liu, Damien Paire, and Fei Gao. "An observer-based switch open-circuit fault diagnosis of DC– DC converter for fuel cell application." *IEEE Transactions on Industry Applications* 56, no. 3 (2020): 3159-3167.
7. Gao, Zhiwei, and Xiaoxu Liu. "An overview on fault diagnosis, prognosis and resilient control for wind turbine systems." *Processes* 9, no. 2 (2021): 300.
8. Zaidi, Abdelaziz, Oscar Barambones, and Nadia Zanzouri. "Implementation of a cascade fault tolerant control and fault diagnosis design for a modular power supply." In *Actuators*, vol. 12, no. 3, p. 135. MDPI, 2023.
9. Khelif, Mohamed Amine, Azeddine Bendiabdelah, and Bilal Djamel Eddine Cherif. "Short-circuit fault diagnosis of the DC-Link capacitor and its impact on an electrical drive system." *International Journal of Electrical and Computer Engineering (IJECE)* 10, no. 3 (2020): 2807-2814.
10. Ren, Xiaogeng, Chunwang Li, Xiaojun Ma, Fuxiang Chen, Haoyu Wang, Ashutosh Sharma, Gurjot Singh Gaba, and Mehedi Masud. "Design of multi- information fusion based intelligent electrical fire detection system for green buildings." *Sustainability* 13, no. 6 (2021): 3405.
11. Odongo, George Y., Richard Musabe, Damien Hanyurwimfura, and Abubakar Diwani Bakari. "An efficient LoRa-enabled smart fault detection and monitoring platform for the power distribution system using self- powered IoT devices." *IEEE Access* 10 (2022): 73403-73420.
12. Ahsan, Mominul, Siew Hon Teay, Abu Sadat Muhammad Sayem, and Alhussein Albarbar. "Smart clothing framework for health monitoring applications." *Signals* 3, no. 1 (2022): 113-145.
13. Sheta, Ahmed N., Gabr M. Abdulsalam, Bishoy E. Sedhom, and AbdelfattahA. Eladl. "Comparative framework for AC-microgrid protection schemes: challenges, solutions, real applications, and future trends." *Protection and control of modern power systems* 8, no. 2 (2023): 1-40.
14. Zhao, Jianfeng, Haibo Feng, Qian Chen, and Borja Garcia De Soto. "Developing a conceptual framework for the application of digital twin technologies to revamp building operation and maintenance processes." *Journal of Building Engineering* 49 (2022): 104028.
15. Nsaif, Younis M., MS Hossain Lipu, Afida Ayob, Yushaizad Yusof, and Aini Hussain. "Fault detection and protection schemes for distributed generation integrated to distribution network: Challenges and suggestions." *IEEE access* 9 (2021): 142693-142717.
16. Ren, Xiaogeng, Chunwang Li, Xiaojun Ma, Fuxiang Chen, Haoyu Wang, Ashutosh Sharma, Gurjot Singh Gaba, and Mehedi Masud. "Design of multi- information fusion based intelligent electrical fire detection system for green buildings." *Sustainability* 13, no. 6 (2021): 3405.



17. Pardeshi, Dr KP. "Implementation of fault detection framework for healthcare monitoring system using IoT, sensors in wireless environment." *Telematique* 21, no. 1 (2022): 5451-5460.
18. Krishnamoorthy, Murugaperumal, Md Asif, Polamarasetty P. Kumar, Ramakrishna SS Nuvvula, Baseem Khan, and Ilhami Colak. "A design and development of the smart forest alert monitoring system using IoT." *Journal of sensors* 2023, no. 1 (2023): 8063524.
19. Mekki, I., A. Kessar, R. Mouaz, M. Ahmed, E. M'Naouer, and A. Oran. "Design of a printed circuit board for real-time monitoring and control of pipeline's cathodic protection system via IoT and a cloud platform." *International Journal of Engineering* 36, no. 9 (2023): 1667-1676.
20. Macrae, Carl. "Learning from the failure of autonomous and intelligent systems: Accidents, safety, and sociotechnical sources of risk." *Risk analysis* 42, no. 9 (2022): 1999-2025.