

A Smart Home Appliance Control System for Physically Disabled People

Dr.P.Sivasankaran 

Assistant Professor, Department of Electronics and Communication Engineering,
Sengunthar Engineering College (Autonomous), Tiruchengode, India

psivasankaran.ece@scteng.co.in

<https://orcid.org/0009-0005-2203-6682>

MD Irshad, Rasid Anwar F

²UG Scholar, Department of Electronics and Communication Engineering,
Sengunthar Engineering College (Autonomous), Tiruchengode, India

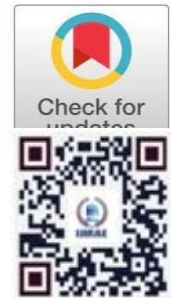

Publication History

Manuscript Reference No: IJIRAE/RS/Vol.13/Issue03/AEMR26.MRAE10132

Research Article | Open Access | Double-Blind Peer-Reviewed | Article ID:IJIRAE/RS/Vol.13/Issue03/AEMR26.MRAE10132

Received:22,February 2026, Revised: 01, March 2026, Accepted: 16,March 2026,Published Online: 25, March 2026.

<https://www.ijirae.com/volumes/Vol13/iss-03/53.AEMR26.MRAE10132.pdf>

Article Citation: Dr.Sivasankaran,Irshad,Rasid(2026),A Smart Home Appliance Control System for Physically Disabled People,IJIRAE: International Journal of Innovative Research in Advanced Engineering, Volume 13, Issue 03 of 2026 pages 433-440 **Doi:->** <https://doi.org/10.26562/ijirae.2026.v1303.53>

BibTeX Key: Dr.Sivasankaran@2026Smart

IJIRAE papers should be cited as IJIRAE (International Journal of Innovative Research in Advanced Engineering, AM Publications, India 2025, ISSN 2349-2163, <https://doi.org/10.26562/ijirae.2026.v1303.53> The journal's official abbreviation is IJIRAE. Orcid: <https://orcid.org/0009-0004-9398-7488>

About the License: Copyright©2026 copyright by the authors. This article is an open access and license under the terms and conditions of the Creative Commons Attribution (CC BY) license (<https://creativecommons.org/licenses/by/4.0/>).

Abstract: This project presents a Smart Home Appliances Control System for Physically Disabled People, developed as an affordable, dependable, and easy-to-use solution for operating household electrical devices. The system is centered on an Arduino Uno, which acts as the main controller, while an HC-05Bluetooth module provides wireless communication between the user's smartphone and the hardware setup. Relay modules are used to safely control the switching of electrical appliances. The user can interact with the system through a smartphone application, either by pressing control buttons or by giving voice commands, which makes the system more accessible and convenient for individuals with physical disabilities. The Bluetooth module receives these commands from the phone and forwards them to the Arduino through UART serial communication. The Arduino then interprets the received instructions and activates the appropriate relay channel to turn the connected appliance ON or OFF. The Phase-2 implementation shows clear improvement in terms of system stability, hardware integration, and overall performance. It successfully demonstrates the independent control of multiple loads, confirming that the design is practical for real indoor home automation use. Overall, the project is effective in combining accessibility, low cost, and functional automation, making it a promising assistive technology solution for improving the independence and quality of life of physically disabled users.

Keywords: Smart Home Automation, Physically Disabled People, Arduino Uno, HC-05 Bluetooth Module, Relay Control, Smartphone Application, Voice Commands, Wireless Communication.

INTRODUCTION

With the rapid advancement of technology, home automation systems have become increasingly popular for improving comfort, e, and security in modern households. However, for physically disabled individuals, smart home technology is not just a matter of convenience it is a necessity that promotes independence and enhances quality of life. Many physically challenged and elderly people face difficulties in performing simple daily tasks such as turning lights on or off, operating fans, or managing other electrical appliances. These challenges highlight the need for an accessible and affordable smart home solution specifically designed to assist them. The "Smart Home Appliances Control System for Physically Disabled People" aims to address this need by developing a reliable and user-friendly system that allows easy control of household devices. The proposed system utilizes a microcontroller-based platform, specifically Arduino Uno, integrated with wireless communication technology such as Bluetooth. Through a mobile application interface, users can send commands to control appliances remotely without physical effort. The system operates by receiving wireless signals, processing them through the microcontroller, and activating relays that control connected electrical loads. The project focuses on simplicity, cost-effectiveness, and ease of implementation, making it suitable for practical home use. It also ensures safety by isolating low-voltage control circuits from high voltage appliances. The design is first verified using simulation tools before hardware implementation, reducing risks and improving reliability. Overall, this project demonstrates how embedded systems and wireless communication can be combined to create an assistive smart home environment. By leveraging modern technology, the system empowers physically disabled individuals to perform daily activities independently, thereby improving their comfort, safety, and overall living standards. Home automation is one of the most important applications of embedded systems in modern technology.

It improves comfort, safety, and energy efficiency by allowing users to control electrical devices intelligently. However, physically disabled and elderly individuals often face difficulties in performing basic household tasks such as switching ON or OFF appliances, which reduces their independence. To address this issue, this project titled “A Smart Home Appliances Control System for Physically Disabled People” proposes a Bluetooth-based wireless control system. The system uses an Arduino Uno microcontroller, an HC-05 Bluetooth module, and relay modules to control household appliances.

I. LITERATURE SURVEY

- ¹**Alvarez, F., & Martinez, L. (2025)** – Conducted environmental stress testing on wearable medical sensors used in outdoor healthcare monitoring systems. Their study examined how environmental conditions such as temperature, humidity, and dust influence sensor performance. They proposed IP-rated protective enclosures to enhance device durability. This work highlights the need for reliable hardware protection in long-term health monitoring.
- ²**Antony Pradeesh, D., & Subiramaniam, N. P. (2025)** – Proposed an IoT-based smart healthcare system integrating LoRa communication with deep learning algorithms. The system collects patient vital parameters and analyzes them using predictive models. Their method improves early detection of abnormal health conditions. This research demonstrates the effectiveness of combining IoT and AI in healthcare monitoring.
- ³**Balasubramanian, R., & Krishnan, V. (2025)** – Presented an IoT-based healthcare monitoring system designed for long-range communication. They introduced adaptive routing protocols to reduce packet loss during wireless transmission.
- ⁴**Banerjee, R., & Chatterjee, S. (2025)** – Focused on validating physiological datasets used in health monitoring systems. They proposed synchronized ground-truth testing protocols to evaluate system performance accurately. Their research highlights the importance of reliable data collection and validation. This work supports the development of trustworthy healthcare technologies.
- ⁵**Chen, L., & Zhang, H. (2025)** – Researched digital filtering techniques used in biomedical signal processing. They proposed adaptive noise cancellation algorithms to reduce motion artifacts in wearable PPG sensors. Their approach improved the accuracy of heart rate and SpO₂ measurements. This study enhances signal quality in wearable healthcare devices.
- ⁶**Desai, P., & Shah, K. (2025)** – Analyzed packet retransmission mechanisms in LPWAN-based healthcare systems. Their research focused on improving data reliability during critical health monitoring situations. They proposed techniques to reduce data loss in wireless communication. This study contributes to more reliable healthcare IoT networks.
- ⁷**Fernandez, G., & Torres, A. (2025)** – Investigated the durability of wearable medical sensors under varying environmental conditions. Their study evaluated long-term performance of sensors in real-world healthcare applications. The research highlighted the importance of robust materials and device protection. This work supports the development of reliable wearable medical devices.
- ⁸**Iyer, K., & Raman, S. (2025)** – Studied battery management strategies for wearable healthcare devices. They proposed duty cycling and deep-sleep scheduling techniques to minimize power consumption. Their approach significantly increased the battery life of medical monitoring systems. This research supports long-term remote patient monitoring.
- ⁹**Kapoor, U., & Sharma, R. (2025)** – Conducted a social acceptance study on wearable emergency healthcare devices. Their research analyzed factors such as usability, comfort, and user trust. The study found that simple and intuitive designs improve device adoption. This research emphasizes the importance of human-centered design in healthcare technology.
- ¹⁰**Kumar, D., & Singh, P. (2025)** – Discussed clinical validation standards and regulatory requirements for remote healthcare systems. Their study emphasized safety, accuracy, and compliance with medical device regulations. They highlighted the importance of standardized evaluation methods. This work supports reliable deployment of healthcare monitoring systems.
- ¹¹**Lavanya, P., & Ramesh, K. (2025)** – Introduced a machine learning-assisted LoRa health monitoring framework. Their system used CNN and LSTM models to predict variations in patient vital parameters. The approach enabled predictive healthcare analytics for early disease detection. This research shows the potential of AI in healthcare monitoring systems.
- ¹²**Lee, S., & Park, J. (2025)** – Focused on security mechanisms for IoT-based healthcare networks. They proposed encryption techniques and secure boot mechanisms to protect patient data. Their research improved data privacy in LoRa communication systems. This study addresses cyber security challenges in healthcare IoT.
- ¹³**Mehta, R., & Shah, D. (2025)** – Analyzed LoRaWAN scalability issues in healthcare IoT networks. They proposed adaptive data rate optimization to maintain stable communication. Their research focused on improving connectivity in rural healthcare environments. This work supports large-scale remote patient monitoring systems.
- ¹⁴**Morales, E., & Rodriguez, P. (2025)** – Studied alarm fatigue in telemedicine monitoring systems. They proposed intelligent threshold optimization to reduce false emergency alerts. Their approach improved system efficiency and medical response time. This research highlights the importance of accurate alert mechanisms in healthcare monitoring.
- ¹⁵**Morales, J., & Diaz, L. (2025)** – Examined ethical and privacy concerns in continuous health monitoring systems. Their research discussed responsible deployment practices for IoT healthcare technologies. They emphasized patient data protection and informed consent. This work contributes to ethical healthcare technology development.
- ¹⁶**Narayanan, K., & Reddy, P. (2025)** – Investigated optimal sensor placement techniques in wearable medical devices. Their research focused on improving signal quality and measurement consistency. The study evaluated different sensor positions on the human body. This work enhances the accuracy of wearable healthcare monitoring.

¹⁷**Nguyen, H., & Tran, T. (2025)** – Explored anomaly detection techniques for physiological signal monitoring. They used machine learning models to identify abnormal patterns in patient data. Their approach reduced false alarms in continuous monitoring systems. This research improves automated healthcare diagnostics.

¹⁸**Rajan, T., & Menon, A. (2025)** – Introduced a hybrid communication system combining LoRa and GSM modules. The system ensured reliable emergency alerts even during network failures. Their design improved redundancy in healthcare communication systems. This research enhanced reliability in remote patient monitoring.

¹⁹**Rao, N., & Gupta, S. (2025)** – Studied human-centered design approaches for wearable emergency devices. They recommended simple panic buttons and vibration alerts for elderly users. Their design improved accessibility and usability. This research highlights the importance of user-friendly healthcare devices.

²⁰**Santos, P., & Oliveira, M. (2025)** – Investigated the use of edge computing in wearable healthcare devices. Their system performed local data processing to reduce communication delay. This approach improved emergency response time. The research demonstrates the benefits of edge computing in healthcare monitoring.

3. PROPOSED SYSTEM

3.1 INTRODUCTION

The proposed model presents a smart and assistive home automation system designed to help physically disabled individuals operate household appliances through voice and Bluetooth communication. The system is developed using an Arduino Uno microcontroller, an HC-05 Bluetooth module, a 4-channel relay board, and electrical loads such as bulbs or fans. The main purpose of this design is to create a low-cost, simple, and reliable solution that improves user independence. Unlike traditional manual switches, this system enables wireless control through a smartphone, eliminating the need for physical movement.

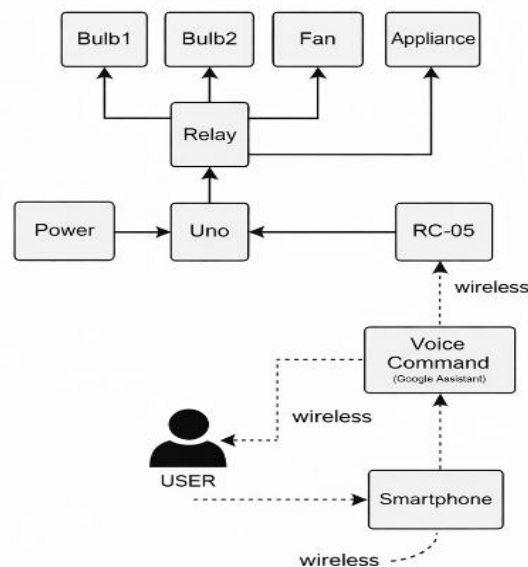

Figure 3.1. Block Diagram of Proposed System.

3.2 Working Principle

Transmitter Section

The transmitter section is responsible for sending control commands from the user to the smart home system. In this project, the transmitter mainly consists of a smartphone (with a mobile application) and an HC-05 Bluetooth module connected to the Arduino Uno. When the user presses a button in the mobile application (for example, to turn ON a light), the application generates a specific command signal in the form of serial data. This data is transmitted wirelessly via Bluetooth. The HC-05 Bluetooth module, which is paired with the smartphone, receives the transmitted signal.

Receiver Section

The receiver section consists of the HC-05 Bluetooth module (receiving side), Arduino Uno microcontroller, relay module, and connected electrical appliances. Once the Bluetooth module receives the wireless command from the smartphone, it forwards the data to the Arduino Uno. The Arduino acts as the main processing unit of the system.

3.3 KEY FEATURES:

Wireless-Control: Appliances can be controlled wirelessly using Bluetooth communication through a smartphone application.

User Friendly Interface: Simple mobile application with clearly labeled ON/OFF buttons for easy operation by physically disabled and elderly users.

Low-Cost Implementation: Uses affordable components such as Arduino Uno, HC-05 Bluetooth module, and relay modules, making it budget-friendly.

Real Time Operation: Instant response to user commands with minimal delay in switching appliances.

Safe Electrical Isolation: Relay module provides isolation between low voltage control circuit and high-voltage household appliances, ensuring safety.

3.4 TRANSMITTER:

Smartphone (Android Application): Acts as the source of control commands. The user sends ON/OFF instructions through the mobile application.

Bluetooth Module (HC-05): Transmits the control commands wirelessly from the smartphone to the Arduino system using Bluetooth communication.

Bluetooth Module (HC-05): Receives the wireless control commands transmitted from the smartphone application and forwards the serial data to the Arduino Uno.

Arduino Uno (Microcontroller): Decodes and processes the received commands. Based on the programmed logic, it generates output signals to control the connected appliances.

Relay Module: Acts as an electrically operated switch that safely connects or disconnects the AC power supply to the household appliances according to the Arduino's signal.

Home-Appliances: Electrical devices such as lights, fans, and other household equipment that are controlled through the relay switching mechanism.

LCD-Display: Displays the status of appliances (ON/OFF) to provide visual feedback to the user.

3.5 ADVANTAGES OVER PROPOSED SYSTEM:

It is designed using low-cost and easily available components such as Arduino Uno and Bluetooth modules, making it affordable and practical for household implementation. The use of relay modules ensures proper electrical isolation between low-voltage control circuits and high-voltage appliances, thereby improving safety. The system also provides real-time response with minimal delay in switching operations. Additionally, it is expandable, meaning more appliances and sensors can be integrated in the future without major modifications. Overall, the system improves comfort, accessibility, safety, and efficiency in daily home operations.

3.6 HARDWARE COMPONENTS:

1. Arduino-UNO
2. Bluetooth-Module-(HC-05)
3. Relay-Module-(4-Channel)
4. Electrical-Appliances-(Bulbs/Fans)
5. Power-Supply-Unit
6. Supporting Wires and Jumpers

4. SYSTEM REQUIREMENTS

4.1 INTRODUCTION

The system requirements of this project include both the essential hardware and software components needed for proper operation of the smart home control system. The hardware requirements consist of an Arduino Uno, HC-05 Bluetooth module, 4-channel relay module, display unit, connecting wires, power supply, and the electrical appliances to be controlled. The software requirement includes the Arduino Blue Control mobile application, which is used to send commands from the smart phone to the system. These requirements are necessary to ensure smooth communication, reliable appliance control, and effective overall performance of the proposed system.

4.2 SOFTWARE REQUIREMENTS

1. Operating System – Windows / Android OS

The system operates using a smartphone (Android OS) and a computer (Windows OS) for programming and monitoring purposes.

Features: Supports Bluetooth connectivity for wireless communication. Compatible with Arduino IDE for code development. Allows installation of mobile applications for appliance control. Easy configuration and driver support

Purpose in the Project: The operating system provides the environment for developing, uploading, and running the control application. Android OS enables users to send wireless commands, while Windows OS is used for programming and testing.

Programming Language-Embedded C / Arduino IDE: The Arduino IDE is used to write The Code and upload programs to the Arduino Uno microcontroller.

Functions Performed: Reads data received from the Bluetooth module. Processes ON/OFF commands. Controls relay modules through GPIO pins. Displays appliance status (if LCD is used). Handles serial communication via UART

3. Mobile Application / Arduino Blue Control

The mobile application used in this project is Arduino Blue Control. It is an Android-based application designed specifically for controlling Arduino boards via Bluetooth. The application provides customizable buttons that allow users to send predefined ON/OFF commands to the Arduino system. Once paired with the HC-05 Bluetooth module, the application transmits digital signals wirelessly whenever a button is pressed. The interface is simple and easy to understand, making it suitable for physically disabled and elderly individuals

4. Bluetooth Module (HC-05)

The system uses Bluetooth communication through the HC-05 module, which operates using the UART (Universal Asynchronous Receiver Transmitter) protocol. When the user presses a button in the Arduino BlueControl app, the command is transmitted via Bluetooth and received by the HC-05 module. The module then forwards the serial data to the Arduino Uno for processing.

Purpose: Bluetooth communication enables wireless transmission of control commands from the smartphone to the Arduino, ensuring real-time and reliable indoor operation.

4.3 HARDWARE REQUIREMENTS

This chapter explains each component in detail, their interconnection, working principles, and programming logic. The hardware serves as the physical implementation of the control circuit, whereas the software provides the intelligence that processes commands and drives the devices.

1. Bluetooth module (HC-05)

Quantity: 1 The module supports a range of up to 10 meters and communicates through **TX (Transmit)** and **RX (Receive)** pins connected to Arduino's digital pins.



Figure 4.1 Bluetooth Module Features:

Operating Voltage: 3.6–6V
Communication: UART (Serial)
Frequency: 2.4 GHz ISM Band
Range: 10 meters

2. Relay module (4-channel)

Quantity: 4 The **4-channel relay module** acts as bridge between the low-voltage Arduino circuit and high-voltage home appliances. Each relay channel controls one electrical device (bulb / fan). When the Arduino sends a HIGH or LOW signal the relay switches its state accordingly, allowing or cutting off AC power to the appliance. 4 The 4-channel relay module acts as bridge between the low-voltage Arduino circuit and high-voltage home appliances.



Figure 4.2 Relay Module

Features:

Channels: 4 Operating Voltage : 5V DC , Maximum Load : 250V AC/10A , Trigger : Active LOW or Active HIGH

3. Display Module (16*2) Quantity: 1 To use a 16x2 display module, you connect it to a microcontroller like an Arduino, using its data and control pins for power and communication. You then write code to send commands and data to the module's controller chip, which displays characters and graphics on the screen.



Figure 4.3 Display Module Features:

Display Format : 16*2 , Operating Voltage : 5V DC , Interface Type : Parallel (4-Bit/8-Bit) or I2C , Backlight : Green Backlight
I2C Module Pins: GND,VCC, SDA, SCL

4. Arduino UNO

Quantity: 1 The Arduino Uno is used for building electronic projects, especially by hobbyists, students, and beginners. It is a versatile platform for creating interactive objects by controlling LEDs, sensors, motors, and other components through code written in the Arduino IDE. Applications include robotics, home automation, embedded systems, and creating interactive art.

Features:

Arduino Uno applications range from simple home automation and robotics to complex IoT and scientific projects. Common uses include building automated plant watering systems, smart home devices like wireless-controlled appliances and security systems, and creating projects for education like low-cost scientific instruments. Arduino Uno applications range from simple home automation, IoT and scientific projects. It is also used for projects involving GPS tracking, environmental monitoring, and robotics.

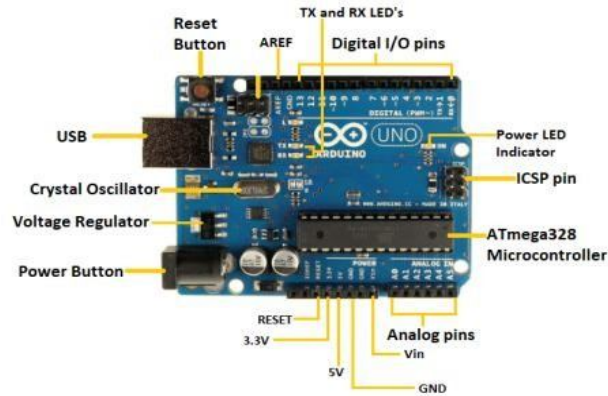

Figure 4.4 Arduino UNO Board

5. Power Supply

Quantity: 2 A stable power supply is required to operate the Raspberry Pi and optical components.



Figure 4.5 Power Supply

Specifications: 5V DC Minimum 2A current Role in Project: Powers Raspberry Pi and laser module

6. Connecting Wires and Jumper Cables , Used for connecting GPIO pins, sensors, and laser modules. Role in Project Provides these electrical interconnections Ensures flexible circuit configuration

5. RESULTS & DISCUSSION:

TRANSMITTER:

The transmitter section of the Smart Home Appliances Control System is a key part of the overall design, as it is responsible for generating and sending control commands to the receiver section. It consists of a smartphone installed with the Arduino BlueControl mobile application, which acts as the main user interface of the system. Through this application, the user can easily select commands such as turning a light, fan, or other connected appliance ON or OFF. Once a button is pressed, the application generates a predefined digital command and transmits it wirelessly using Bluetooth technology. After successful pairing with the HC-05 Bluetooth module, the command is sent in the form of serial data for processing by the Arduino. In this Project. The performance of the transmitter section is highly effective because it enables real-time communication within the normal Bluetooth operating range and removes the need for physical interaction with wall switches. Its simple and user-friendly interface makes it especially suitable for physically disabled users, as it reduces effort and improves accessibility in controlling home appliances. In addition, the use of a smartphone as the transmitting device makes the system more practical and cost-effective, since no separate dedicated remote controller is required. Overall, the transmitter section is reliable, responsive, and convenient, contributing significantly to the successful operation of the smart home automation system.

RECEIVER:

The receiver section of the Smart Home Appliances Control System is responsible for receiving, interpreting, and executing the control commands sent from the transmitter section. It consists of the HC-05 Bluetooth module, Arduino Uno microcontroller, relay module, and the connected household appliances. When the Bluetooth module receives the wireless command from the smartphone, it converts the signal into serial data and sends it to the Arduino Uno through UART communication. The Arduino then continuously reads the incoming data and processes the command based on the program stored in its memory of Microcontroller According to the received instruction, the Arduino activates or deactivates the appropriate digital output pin connected to the relay module. The relay acts as an electrically operated switch that controls the AC power supplied to the connected appliances. When the relay is energized, it closes the circuit and allows current to pass, thereby turning the appliance ON. When the relay is de-energized, it opens the circuit and cuts off the current flow, turning the appliance OFF. The receiver section is highly important because it ensures accurate command execution, safe appliance switching, and reliable coordination between the control signal and the load. Overall, this section demonstrates effective hardware integration and stable performance, making the system suitable for practical indoor smart home applications. The implementation and simulation of the Smart Home Appliances Control System for Physically Disabled People produced reliable and satisfactory results. The system also demonstrated stable performance during continuous operation. Multiple commands were sent sequentially to test the reliability of communication and switching consistency. . When the Bluetooth module receives the wireless command from the smartphone, it converts the signal into serial data and sends it to the Arduino Uno through UART communication. The Arduino then continuously reads the incoming data and processes the command based on the program stored in its memory of Microcontroller According to the received instruction, the Arduino activates or deactivates the appropriate digital output pin connected to the relay module. The relay acts as an electrically operated switch that controls the AC power supplied to the connected appliances. When the relay is energized, it closes the circuit and allows current to pass, thereby turning the appliance ON



Figure 5.1 Transmitter

During testing, each appliance connected through the relay module responded correctly to the ON and OFF commands sent from the mobile application. The Arduino Uno accurately interpreted the received serial data and executed the programmed instructions without errors

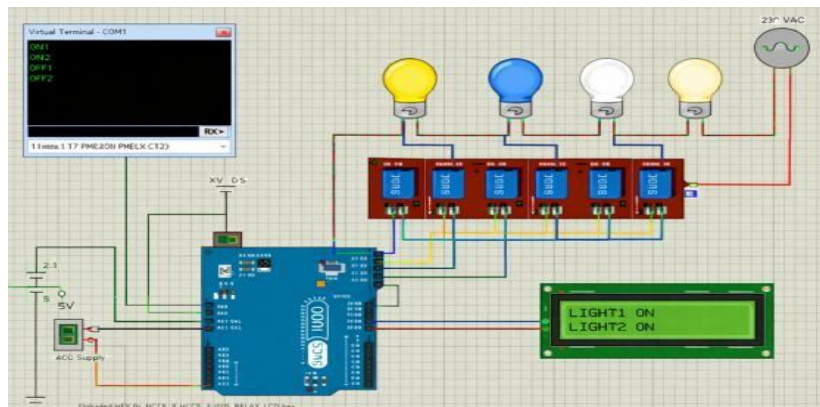

Figure 5.2 Receiver

The system also demonstrated stable performance during continuous operation. Multiple commands were sent sequentially to test the reliability of communication and switching consistency. No data loss or command mismatch was observed during repeated trials. The isolation provided by the relay module ensured safe operation between the low-voltage control circuit and high-voltage household appliances.

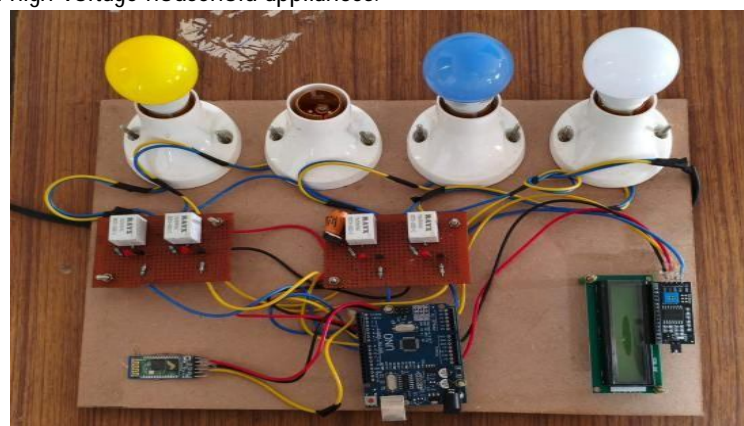

Figure 5.3. Hardware

The discussion of results confirms that the proposed system meets its primary objective of enabling wireless control of home appliances through a simple mobile interface. The system is especially beneficial for physically disabled individuals, as it eliminates the need for physical interaction with wall switches. Overall, the results validate the effectiveness, safety, and practicality of the proposed smart home appliance control system. The results of the Smart Home Appliances Control System for Physically Disabled People show that the proposed system successfully controlled multiple household appliances through Bluetooth communication using the Arduino BlueControl mobile application. During testing, the smartphone was able to send commands effectively to the HC-05 Bluetooth module, and the Arduino Uno accurately processed these commands to switch the connected appliances ON and OFF through the relay module. The system demonstrated stable performance, quick response, and reliable operation within the normal Bluetooth range. The inclusion of a user-friendly mobile interface made the system easy to operate, especially for physically disabled users, reducing the need for manual switching.

The discussion of the project confirms that the system is low-cost, simple to implement, and practical for indoor home automation. It also shows that integrating smartphone control, Bluetooth technology, and relay-based switching can provide an efficient assistive solution that improves accessibility, convenience, and independence in daily life.

6. CONCLUSION

The proposed Smart Home Appliances Control System for Physically Disabled People was successfully designed, simulated, and implemented. The system effectively demonstrates wireless control of household appliances using Arduino Uno and Bluetooth communication. It provides a simple, affordable, and reliable solution that reduces physical effort and increases independence for physically disabled and elderly individuals. The system was tested through simulation and hardware implementation, and the results confirmed accurate command transmission, proper relay switching, and stable operation. Although the current prototype fulfills its basic objective, there is considerable scope for further enhancement to improve performance, scalability, and intelligence.

REFERENCES

1. N.Sriskanthan and F. an, "Bluetooth based home automation system," *Microprocessors and Microsystems*, vol. 26, no. 6, pp. 281–289, 2002.
2. A.R.Al-Ali and M.Al-Rousan, "Java-based home automation system," *IEEE Transactions on Consumer Electronics*, vol. 50, no. 2, pp. 498–504, 2004.
3. D.J.Cook and S.K.Das, "How smart are our environments? An updated look at the state of the art," *Pervasive and Mobile Computing*, vol. 3, no. 2, pp. 53–73, 2007.
4. T.Perumal, A.R.Ramli, and C.Y.Leong, "Interoperability framework for smart home systems," *IEEE Transactions on Consumer Electronics*, vol. 54, no. 4, pp. 1918–1925, 2008.
5. K.Gill, S.H.Yang, F.Yao, and X.Lu, "A ZigBee-based home automation system," *IEEE Transactions on Consumer Electronics*, vol. 55, no. 2, pp. 422–430, 2009.
6. A.EIshafee and K.A.Hamed, "Design and implementation of a WiFi based home automation system," *World Academy of Science, Engineering and Technology*, vol. 68, pp. 2177–2180, 2012.
7. R.A.Ramlee, M.H.Leong, R.S.Singh, M.M.Ismail, M.A. Othman, H.A. Sulaiman, M.H.Misran, and M.A.Meor Said, "HC-05 Bluetooth remote home automation system using Android application," *International Journal of Engineering Science*, vol. 2, no. 1, pp. 149–153, 2013.
8. Y.H.Kim, J.S.Choi, and I.H.Suh, "Voice recognition based smart home system," in *Proc. IEEE Int. Conf. Consumer Electronics (ICCE)*, 2014, pp. 484–485.
9. S.Madakam, R.Ramaswamy, and S.Tripathi, "Internet of Things (IoT): A literature review," *Journal of Computer and Communications*, vol. 3, no. 5, pp. 164–173, 2015.
10. S.R.Bharanidharan and B.Shanthi, "Wireless home automation system using IoT," *International Journal of Computer Applications*, vol. 116, no. 17, pp. 15–19, 2015.
11. B.K.Bose, "Voice-controlled home automation system for physically disabled people," *International Journal of Engineering Research and Technology (IJERT)*, vol. 4, no. 3, pp. 722–725, 2015.
12. P.S.Sontakke and S.A.Sontakke, "Arduino based voice controlled home automation system," *International Journal of Advanced Research in Computer Science and Software Engineering*, vol. 4, no. 6, pp. 438–442, 2016.
13. S.A.Ali, A.Rehman, S.A.Khan, and M.U.Ali, "Smart home automation system using Bluetooth technology," in *Proc. IEEE Int. Conf. Signal Processing and Communication (ICSPC)*, 2016, pp. 1–5.
14. M.R.Palattella, N.Accettura, X.Vilajosana, T.Wattheyne, L.Grieco, G.Boggia, and M.Dohler, "Internet of Things in the 5G era," *IEEE Journal on Selected Areas in Communications*, vol. 34, no. 3, pp. 510–527, 2016.
15. S.N.G.Gour and P.R.Tiwari, "Design of smart home system using GSM," *International Journal of Engineering Research*, vol. 6, no. 4, pp. 234–238, 2017.
16. M.A.Mazidi, J.Naimi, and R.D.McKinlay, "Embedded system based smart appliance control," in *Proc. IEEE Conf. on Embedded Systems*, 2017, pp. 112–116.
17. S.H.Lee, J.H.Park, and H.Y.Kim, "Smart home monitoring and control using Android," *IEEE Consumer Electronics Magazine*, vol. 7, no. 3, pp. 29–35, 2018.
18. A.Z.Aikar and U.Buhur, "An IoT-based smart home automation system," *IEEE Transactions on Consumer Electronics*, vol. 64, no. 4, pp. 429–437, 2018.
19. J.Bangali and A.Shaligram, "Design and implementation of security systems for smart home," in *Proc. IEEE Int. Conf. on Electronics and Communication Systems*, 2019, pp. 473–477.
20. R.Piyare and M.Tazil, "Bluetooth based home automation system using smartphone," *International Journal of Engineering Research & Technology*, vol. 9, no. 6, pp. 1050–1054, 2020.