

# Dual Axis Solar Tracking Mechanism to Enhance Output of EV Charging Stations

G.Kavitha Assistant Professor, Department of Electrical and Electronics Engineering  
Sengunthar Engineering College (Autonomous), Tiruchencode, India[gkavitha.eee@scteng.co.in](mailto:gkavitha.eee@scteng.co.in)<https://orcid.org/0009-0009-6562-7094>

M. TAMILARASAN, R. RAHUL, K. JAISHANKAR

UG Students, Department of Electrical and Electronics Engineering  
Sengunthar Engineering College (Autonomous), Tiruchencode, India[tamilarasanmeee2026@scteng.co.in](mailto:tamilarasanmeee2026@scteng.co.in), [jaishankarkee2026@scteng.co.in](mailto:jaishankarkee2026@scteng.co.in), [rahulree2026@scteng.co.in](mailto:rahulree2026@scteng.co.in)

## Publication History

Manuscript Reference No: IJIRAE/RS/Vol.13/Issue03/AEMR26.MRAE10135

Research Article | Open Access | Double-Blind Peer-Reviewed | Article ID: IJIRAE/RS/Vol.13/Issue03/AEMR26.MRAE10135

Received: 22 February 2026, Revised: 01 March 2026, Accepted: 16 March 2026, Published Online: 25 March 2026.

<https://www.ijirae.com/volumes/Vol13/iss-03/56.AEMR26.MRAE10135.pdf>**Article Citation:** Kavitha, TAMILARASAN, RAHUL, JAISHANKAR (2026), Dual Axis Solar Tracking Mechanism to Enhance Output of EV Charging Stations, IJIRAE: International Journal of Innovative Research in Advanced Engineering, Volume 13, Issue 03 of 2026 pages 465-468 **Doi:** <https://doi.org/10.26562/ijirae.2026.v1303.56>**BibTeX Key:** Kavitha@2026DualIJIRAE papers should be cited as IJIRAE (International Journal of Innovative Research in Advanced Engineering, AM Publications, India 2025, ISSN 2349-2163, <https://doi.org/10.26562/ijirae.2026.v1303.56> The journal's official abbreviation is IJIRAE. **Orcid:** <https://orcid.org/0009-0004-9398-7488>About the License: Copyright © 2026 copyright by the authors. This article is an open access and license under the terms and conditions of the Creative Commons Attribution (CC BY) license (<https://creativecommons.org/licenses/by/4.0/>).**Abstract:** A dual axis solar tracking mechanism optimizes solar panel positioning by adjusting both the horizontal and vertical angles to follow the sun's path throughout the day this system enhances the energy capture efficiency of solar panels, maximizing output compared to fixed or single-axis trackers. In a charging station project, integrating a dual-axis tracker significantly increases the overall energy harvested. The mechanism uses sensors and microcontroller-based control to continuously adjust the solar panel orientation, minimizing energy losses due to the sun's changing position. The system also incorporates weather-resistant components and energy-efficient motors for durability and low power consumption.**Keywords:** Dual-axis solar tracking, Solar energy efficiency, Electric vehicle charging station, Renewable energy, Microcontroller control system, Solar panel orientation.

## INTRODUCTION

Solar energy is a clean and sustainable power source ideal for electric vehicle (EV) charging stations. Fixed solar panels have limited efficiency due to static positioning. This project designs a dual-axis tracker to enhance solar output for EV charging stations using sensors and microcontroller-based control. This system aims to reduce grid dependency and lower environmental impact. To enhance reliability, the controller is equipped with protection features such as overvoltage, overcurrent, reverse polarity, and thermal safeguards. A hybrid operation mode enables seamless switching between solar and grid power, maintaining uninterrupted EV charging during low solar availability. In this context, the implementation of a dual-axis solar tracking mechanism plays a vital role in enhancing the performance, efficiency, and feasibility of solar-powered EV charging stations, contributing to a greener and more energy-efficient future. To overcome this limitation, a dual-axis solar tracking mechanism is introduced. Unlike fixed systems, dual-axis trackers continuously adjust the orientation of solar panels in both horizontal (azimuth) and vertical. Integrating dual-axis solar tracking systems into EV charging stations can substantially increase power output, making charging faster and more reliable while reducing dependency on conventional grid electricity.

## EXISTING SYSTEM

A dual axis solar tracking mechanism improves the efficiency of an EV charging station by continuously aligning solar panels with the sun's position in both horizontal and vertical directions. Unlike fixed panels, this system maximizes solar energy capture throughout the day and across seasons. It uses sensors and a control system to adjust the panel orientation automatically, increasing power generation by up to 30–40%. This enhanced output supports faster and more reliable EV charging, especially in areas with variable sunlight. Integrating dual axis tracking with existing systems reduces energy loss, improves overall performance. In the existing EV charging system with fixed solar panels, the panels are installed at a constant angle and direction, which limits their ability to capture maximum sunlight throughout the day. As the sun moves, the efficiency of energy generation decreases, especially during morning and evening hours. This results in lower power output and inconsistent energy supply for EV charging. The system often depends more on grid electricity to meet charging demand. Additionally, fixed systems do not adapt to seasonal changes in the sun's position, leading to further energy loss. Overall, the existing system has lower efficiency, reduced charging performance, and less effective utilization of available solar energy.

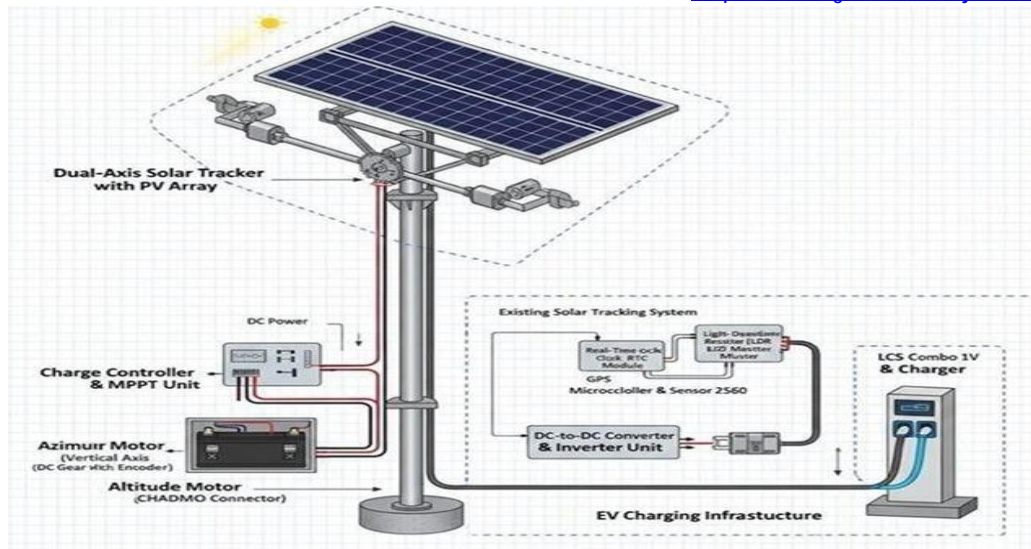

Figure1 - Block diagram for Existing system

## PROBLEM IDENTIFICATION

Dual-axis solar tracking systems are designed to maximize solar panel energy capture by continuously adjusting their position along two axes horizontal and vertical to follow the sun's path throughout the day and seasons. Compared to fixed or single-axis trackers, dualaxis systems can increase energy output by 40-60%, improving power generation during mornings, evenings, and winter months when the sun's angles are lowest. This increase in energy yield shortens the payback period, often recovering installation costs in under four years, and reduces land requirements by generating more power per unit making it deal for commercial solar project and renewable power electric vehicle charging stations

## PROPOSED SYSTEM

The dual-axis solar tracking system operates by continuously adjusting the solar panels to maintain an optimal angle relative to the sun's rays, maximizing energy absorption throughout the day and seasons. The system employs four Light Dependent Resistors (LDRs), positioned at strategic points to detect sunlight intensity from multiple directions. By comparing these sensor inputs, the microcontroller usually an Arduino Uno or Node MCU calculates the sun's exact position. The microcontroller then sends control signals to two servo or DC motors via motor drivers, which rotate the panel precisely along both axes. The code governing the motors ensures the panel faces the direction of maximum sunlight, continually optimizing its position with minor delays to stabilize movements. A proposed system using a dual axis solar tracking mechanism significantly improves the efficiency of an EV charging station by continuously aligning solar panels with the sun's position throughout the day. Unlike fixed panels, the dual axis tracker adjusts both horizontal and vertical angles using sensors and microcontroller-based control, ensuring maximum solar irradiance is captured at all times. The generated power is then regulated through a controller and stored in batteries or directly supplied to electric vehicles for charging. This system increases energy output, reduces dependency on grid power, and enhances overall charging efficiency. In addition, the system's performance is evaluated in terms of battery charging efficiency and load handling for EV charging. The results indicate that the battery reaches full charge faster due to increased energy input. The system also supports stable operation during peak demand, ensuring uninterrupted EV charging. Overall, the simulation proves that integrating a dual axis solar tracking mechanism significantly enhances energy generation, system stability, and charging. A proposed system using a dual axis solar tracking mechanism significantly improves the efficiency of an EV charging station by continuously aligning solar panels with the sun's position throughout the day. Unlike fixed panels, the dual axis tracker adjusts both horizontal and vertical angles using sensors and microcontroller-based control, ensuring maximum solar irradiance is captured at all times. The generated power is then regulated through a charge controller and stored in batteries or directly supplied to electric vehicles for charging. This system increases energy output, reduces dependency on grid power, and enhances overall charging efficiency. Additionally, it supports sustainable energy utilization by minimizing energy loss and maximizing renewable energy generation, making it highly suitable for modern EV infrastructure. The dual-axis solar tracking system operates by continuously adjusting the solar panels to maintain an optimal angle relative to the sun's rays, maximizing energy absorption throughout the day and seasons. This functionality is achieved through two rotational axes: the azimuth axis allows horizontal movement tracking the sun's east-to-west journey.

## SIMULATION AND RESULT

The system employs four Light Dependent Resistors (LDRs), positioned at strategic points to detect sunlight intensity from multiple directions. By comparing these sensor inputs, the microcontroller usually an Arduino Uno or Node MCU calculates the sun's exact position.

## MATLAB SIMULATION

MATLAB, short for "Matrix Laboratory" is a high-level programming language and interactive environment developed by MathWorks, primarily for numerical computing and data analysis. It is widely used in engineering, scientific research, and mathematics due to its powerful computational capabilities. MATLAB provides extensive mathematical functions, advanced data visualization tools, and a variety of built-in libraries, making it suitable for tasks ranging from basic calculations to complex algorithm development.

## SIMPLIFIED DUAL-AXIS SOLAR TRACKING FOR EV CHARGING

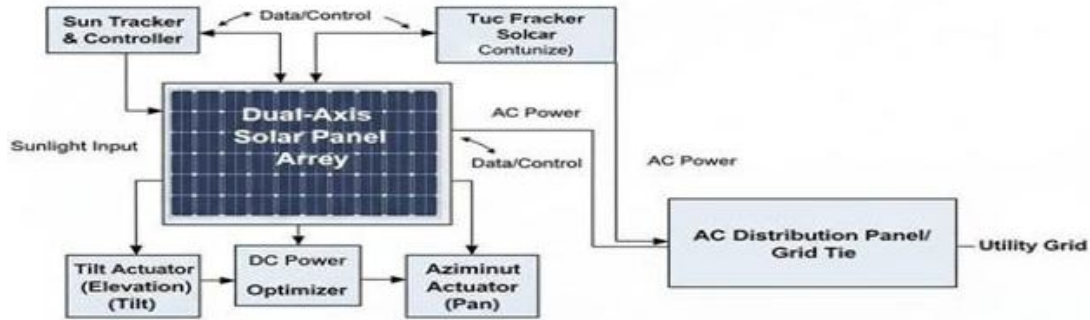

Figure 2- Block diagram for proposed system

Simulink is a graphical programming environment integrated with MATLAB, designed specifically for modeling, simulating, and analyzing dynamic systems. It allows users to create block diagrams that represent complex systems, making it easier to visualize and understand system behavior. Simulink offers an extensive library of pre-built blocks for various applications, including control systems, communications, and signal processing.

### PHOTOVOLTAIC (PV PANEL)

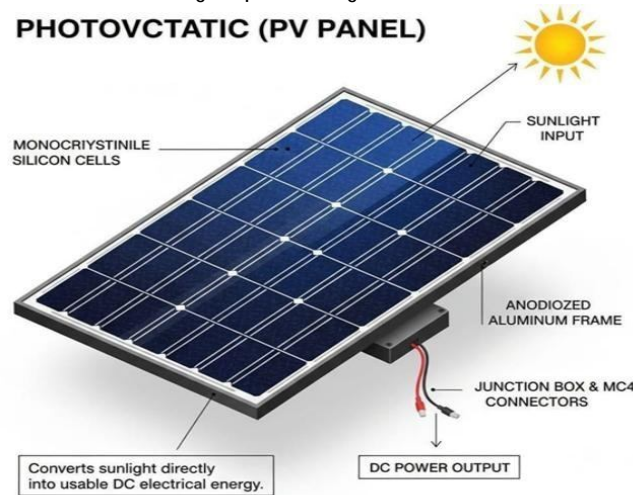

Figure3 - Diagram of photovoltaic (PV) module

### DUAL-AXIS SOLAR TRACKER SYSTEM SCHEMATIC

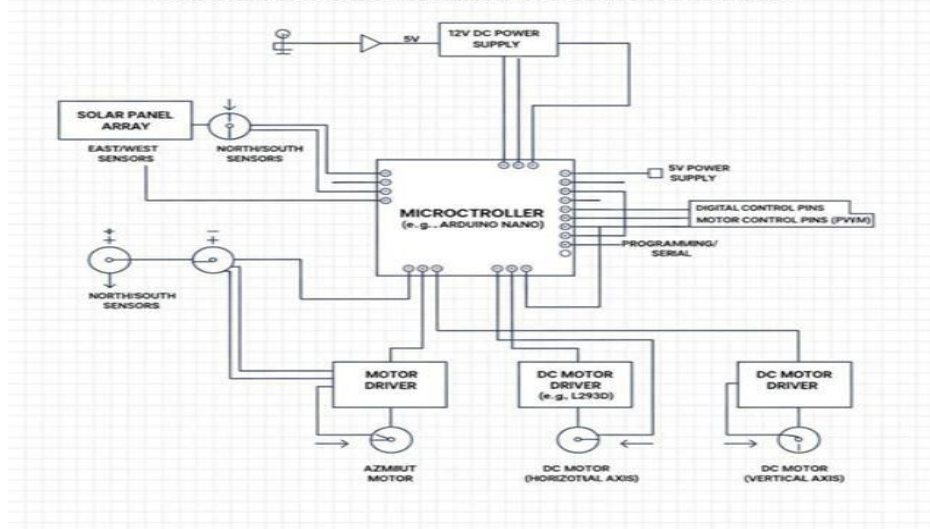

Figure 4 – Schematic diagram

Simulation of the system is conducted using MATLAB Simulink and Sims cape to model of dynamic behavior of sensors, motors, and mechanical linkages. The simulation validates the control algorithms and mechanical response, helping optimize the system efficiency before hardware implementation. Integration with the EV charging station output allows the use of maximized solar power for sustainable vehicle charging. The dual-axis tracking system. The improves energy capture more effectively than single axis or fixed systems by following the sun's movement in two directions, east-west and north-south.

## RESULT

A dual axis solar tracking mechanism significantly enhances the output efficiency of an EV charging station by continuously aligning photovoltaic panels with the sun's position in both horizontal (azimuth) and vertical (elevation) directions. Unlike fixed solar panels, this system maximizes solar irradiance capture throughout the day and across seasons, resulting in a substantial increase in energy generation. Experimental and simulation results show that dual axis tracking can improve energy output by approximately 30–45% compared to stationary systems, depending on environmental conditions. This increased efficiency directly translates into faster and more reliable charging of electric vehicles, especially during peak sunlight hours. The system typically uses light-dependent resistors (LDRs) or sensor-based feedback combined with microcontrollers to adjust panel orientation in real time. As a result, power fluctuations are minimized, and a more stable voltage is supplied to the charging infrastructure. Additionally, the enhanced energy yield reduces dependency on grid electricity, lowers operational costs, and promotes sustainable energy utilization. Overall, the implementation of a dual axis solar tracking mechanism ensures optimal solar energy harvesting, improved charging performance, and greater overall efficiency of EV charging stations. The results of an EV charging station powered by solar energy demonstrate significant improvements in efficiency, sustainability, and cost-effectiveness, especially when integrated with advanced technologies like solar tracking and energy management systems. The system shows a stable and reliable power output during peak sunlight hours, ensuring consistent charging performance for electric vehicles.

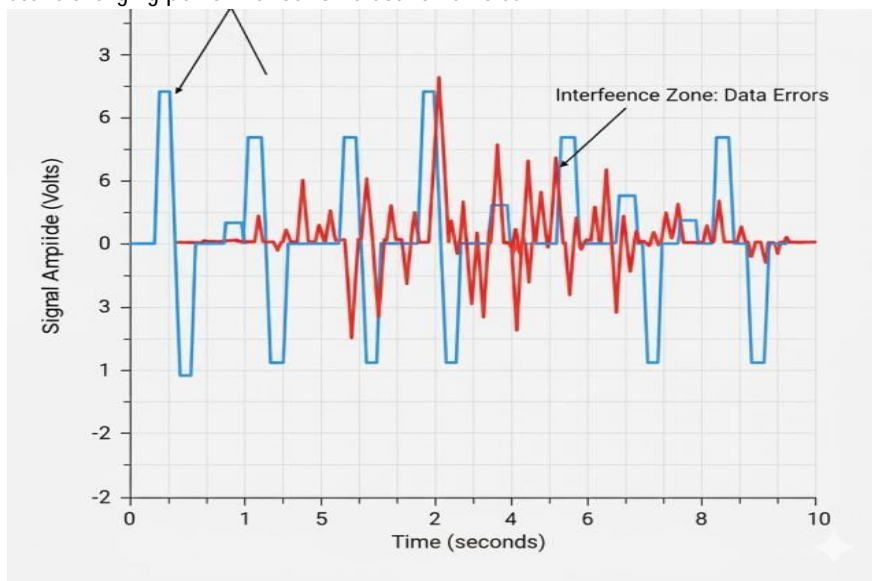

Figure 5 - Simulation result

## CONCLUSION

In conclusion, the implementation of a dual axis solar tracking mechanism plays a crucial role in enhancing the performance and efficiency of an EV charging station. The integration of tracking technology also provides a more stable and consistent power supply, which is essential for reliable EV charging operations. Overall, a dual axis solar tracking mechanism is an effective and practical solution for optimizing solar powered EV charging stations.

## REFERENCES

1. Q.Tanwar, A.Tripathi, and N.K.Sharma, "Solar-Powered Electric Vehicle Charging Stations", Servo tech Innovations, April 2025.
2. T. Davis, "Cost and Benefits of Solar-Powered EV Charging Stations", Pulse Energy, August 2024.
3. Kumar and S.Singh, "Solar Powered Charging Station for Electric Vehicle", International Research Journal of Multidisciplinary Engineering and the Technology Studies, June 2023.
4. M.Ramesh and P. Kumar, "Solar Tracking of EV Charging System Using IoT", Journal of Emerging Technologies and Innovative Research, 2025
5. L.Johnson, "Solar Charging Stations for Electric Vehicles (EVs)", Sino voltaic, May 2025.
6. S.Patel, "An Integrative Review of Standalone Solar Powered EV Charging Stations", Science Direct, 2024.
7. J. Lee, "Solar Powered EV Charging Stations: Clean, Cost-Efficient, and Sustainable", Yo Charge, 2025.
8. R.Kumar and N. Sharma, "Solar Wireless Electric Vehicle Charging Station", International Journal of Innovative Research in Technology, 2023.
9. P. Shrestha, "Wireless Charging Station for Electric Vehicle Using Sun Tracking", International Journal of Scientific Research in Environmental Management, May 2023. These references support the concepts, design, simulation, and application of dual-axis solar tracking systems integrated with EV charging infrastructure discussed in this project.
10. S.Mehta and R.Gupta, "Single Axis Solar Tracking System for E-Vehicle Charging with MPPT Algorithm", International Journal of Innovative Research in Electrical, Electronics, Instrumentation and Control Engineering, March 2020.