



SOLAR PV BASED MAXIMUM POWER POINT TRACKING EMBEDDED VOLTAGE REGULATION FOR MICRO-GRID APPLICATION

Mwaka Juma

Department of Electrical Engineering,
University of Dar es salaam, Tanzania
jumamwaka@gmail.com

Consalva Msigwa

Department of Electrical Engineering,
Dar es salaam Institute of Technology, Tanzania
msigwaj34@gmail.com

Bakari M.M. Mwinyiwiwa

Department of Electrical Engineering,
University of Dar es salaam, Tanzania
bakari1mwinyiwiwa@gmail.com

Manuscript History

Number: IJIRAE/RS/Vol.06/Issue06/JNAE10088

Received: 03, June 2019

Final Correction: 19, June 2019

Final Accepted: 25, June 2019

Published: **June 2019**

Citation: Mwaka, Consalva & Bakari (2019). Solar PV Based Maximum Power Point Tracking Embedded Voltage Regulation for Micro-Grid Application. IJIRAE::International Journal of Innovative Research in Advanced Engineering, Volume VI, 552-558. doi://10.26562/IJIRAE.2019.JNAE10088

Editor: Dr.A.Arul L.S, Chief Editor, IJIRAE, AM Publications, India

Copyright: ©2019 This is an open access article distributed under the terms of the Creative Commons Attribution License, Which Permits unrestricted use, distribution, and reproduction in any medium, provided the original author and source are credited

Abstract—This work deals with voltage regulation of solar photovoltaic based minigrid. In this regulator, DC-DC boost converter embedded with maximum power point Tracking (MPPT) voltage regulation without controlling charging and discharging of batteries through bidirectional converter. The proposed voltage regulator managed to regulate dc voltage and maintaining the dc bus voltage at its reference value. The DC voltage regulation has been done by corrected duty cycle of estimated duty cycle through MPPT controller. The DC voltage regulator was tested at slow varying and moderately varying solar Insolation at Constant Temperature. Simulation results using MATLAB/SIMULINK software show that the DC voltage regulator is capable of regaining voltage regulation after step load changes

Keywords— MPPT; Duty Cycle; Voltage Regulator; Boost Converter; Solar PV;

I. INTRODUCTION

Renewable energy based micro grids are being considered to provide electricity for the expanding energy demand in the grid distribution network and grid isolated areas. As the use of renewable energy sources (RES) as Micro-grids in isolated mode of operation in grid isolated areas increases, the technical challenges associated with the operation and control are enormous. The energy sources from renewable give stochastically variable magnitude AC or DC voltages. This leads a real challenge, especially when it comes to maintaining both micro grid voltage and frequency within an acceptable/standard range [7].

The characteristics of solar cell are dependent upon the insolation, temperature and array voltage. Thus, it is necessary to implement MPPT in order to move the operating voltage close to maximum power point under changing atmospheric conditions. MPPT in solar is important because it reduces the solar array cost by decreasing the number of solar panels needed to obtain the desired output. MPPT capable to produce desired output voltage through Boost converter but not regulated. In order to archive regulated output voltage, there is a need of additional control mechanism such as bidirectional buck-boost converter to control batteries charging and discharging systems. This paper DC-DC boost with MPPT control with direct duty cycle can be corrected to provide voltage regulation which applicable for micro grid systems. The control of dc-dc voltage regulator and inverter interfaced micro grid network that combines diversity of RES is the structure tackled by this research work. As part of continuous research, this paper presents a design of DC bus voltage regulator embedded with MPPT which is mandatory for integration of diverse envisaged electricity sources with stochastic outputs. The DC bus voltage regulators in this case are used to maintain a DC bus voltage at constant value and therefore used as a point of common coupling of several available renewable energy sources as shown in fig.1. The DC voltage common bus was proposed in this paper due to its simplicity to control as compared to AC voltage common bus which needs complex control aspects to achieve synchronization and stable operation.

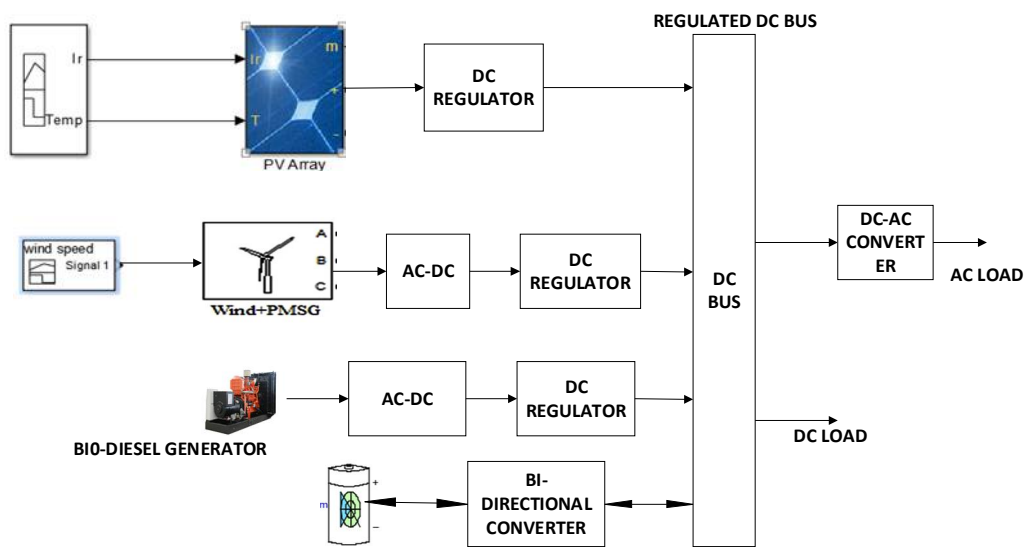

Fig. 1- Micro-grid model for Scalable hybrid renewable energy power generation

II. REVIEW OF THE METHODOLOGIES FOR MAXIMUM POWER POINT TRACKING (MPPT)

The Perturb and Observe (P&O) and the Incremental Conductance (InCond) algorithms are the most commonly applied algorithms used for MPPT. The advantages of both methods are simplicity and requirement of low computational power. Other techniques based on different principles include fuzzy logic control, neural network, fractional open circuit voltage or short circuit current and current sweep. Most of these methods yield a local maximum and some, like the fractional open circuit voltage or short circuit current, give an approximated MPP, rather than an exact output. In this work, the Perturb and Observe (P & O) technique which has been frequently used in PV systems is applied. The flowchart of the P & O algorithm is explained maximum power extraction from solar PV in [4]. An MPPT controller is implemented to maximize the output power of the solar PV by adjusting the duty cycle D as shown in Fig.2.

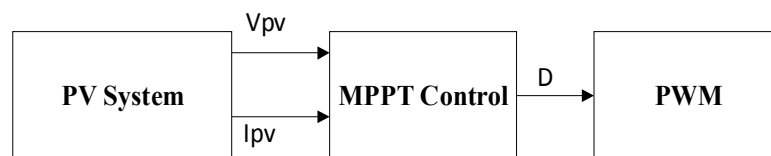

Fig. 2- MPPT Control with direct duty cycle

Traditional MPPT control cannot regulate and keep constant dc voltage as reference value (750V) due to changing of solar Irradiance with constant temperature when step load changes.

III. DC BUS VOLTAGE REGULATION USING DC-DC BOOST CONVERTER

A boost converter is used in renewable step up unregulated dc voltage to a higher voltage that required by loads as shown in Fig. 3. The parameters of dc-dc boost converter are as calculated in [3] by equations (1-5) In dc-dc boost converter the output voltage is greater than the input voltage, can expressed as

$$V_{dc} = \frac{V_{pv}}{1 - D} \quad (1)$$

Where V_{dc} is the output voltage, D is duty cycle, and V_{pv} is input voltage. The output current can be given by;

$$I_{dc} = I_{pv}(1 - D) \quad (2)$$

In order to operate the converter in continuous current conduction mode, the inductance is calculated such that the inductor current I_L flows continuously and never fall to zero as given by (3)

$$L_1 \geq \frac{D(1 - D)^2 R_1}{2f} \quad (3)$$

Where L_1 is the minimum inductance, D is the duty cycle, R_1 is Load resistance, and f is the switching frequency of switch Q_1 in Fig. 4.

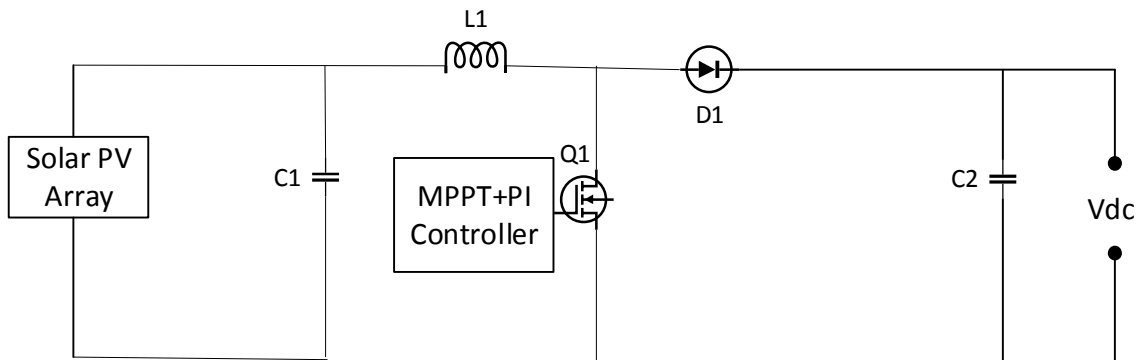

Fig. 3 DC-DC Boost Converter

The output capacitance and input capacitor gave the desired output voltage was calculated as follows; ΔV_o is ripple output voltage being 2% and ΔV is ripple of input voltage equal to 1% as [3]

$$C_2 \geq \frac{D}{\Delta V_o * f * R_1} \quad (4)$$

Therefore, the input capacitor can be calculated as;

$$C_1 \geq \frac{D}{8 * f^2 * L_1 * \Delta V} \quad (5)$$

A. DC Bus Voltage

The minimum DC bus voltage for power transfer should be at least equal to 1.1 of the peak AC line to line voltage as explained in [2].

$$V_{dc} = 1.1 * V_{sab} * \sqrt{2} \quad (6)$$

B. Controller Designed of Voltage Regulator

Control strategy has been developed, in which the new duty cycle was found by comparing an estimated MPPT-based duty cycle D with corrected duty cycle as shown in Fig. 4.

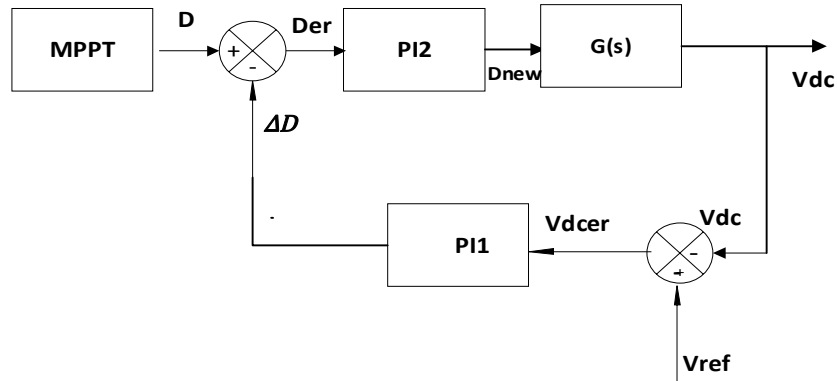

Fig.4 Controller design of DC-DC Boost Converter

The control of the DC-DC Boost Converter is shown in Fig. 3. The DC-DC Boost Converter regulates the DC bus voltage through feedback loop that have been corrected an estimated duty cycle of MPPT control Algorithm. The DC bus voltage is maintained by a proportional integral (PI) controllers, which is expressed as;

$$\Delta D(k) = \Delta D(k - 1) + kp1\{V_{dcer}(k) - V_{dcer}(k - 1)\} + ki1V_{dcer}(k) \quad (7)$$

Where $kp1$ and $ki1$ are the gain of the PI1 controller, respectively.

$$V_{dcer}(k) = V_{ref}(k - 1) - V_{dc}(k) \quad (8)$$

The new duty cycle of the converter governs by PI2 controller and it is estimated as;

$$D_{new}(k) = D_{new}(k - 1) + kp2\{D_{er}(k) - D_{er}(k - 1)\} + ki2D_{er}(k) \quad (9)$$

Where $kp2$ and $ki2$ are the proportional and integral gains of PI2 controller respectively

$$D_{er}(k) = D(k - 1) - \Delta D(k) \quad (10)$$

TABLE1- TESTED PV ARRAY SUNPOWERSPR-315-WHT-D AS SHOWN IN TABLE.1

An Array data	quantity
Parallel String	10
Series-Connected modules per string	10
Number of cells per module	96
Maximum Power	315W
Voltage at maximum power point	54.7V
Current at maximum power point	5.76A

Boost converter calculated parameters are

Inductor $L_1 = 20\text{mH}$, output capacitor $C_2 = 150\mu\text{F}$, $C_1 = 1\mu\text{F}$ and Load $R1 = 17.85\Omega$

Controller Parameter: PI1, $kp1 = 0.5$ and $ki1 = 15$

PI2, $kp2 = 0.25$ and $ki2 = 30$

IV. ANALYSIS AND DISCUSSION OF SIMULATION RESULTS

Simulations based on MATLAB/SIMULINK of Solar PV Tested model is presented, Fig. 5 shows simulation results for moderately varying Solar Irradiance between 800W/m^2 up to 1000W/m^2 when there are step load changes at Constant Temperature. It can be seen that DC voltage regulator is capable to regulate the output DC voltage within 1% of the reference DC bus voltage (750V) and capable of regaining after step changes of the load.

Case1: At moderate changes of Solar Irradiance at step load Changes

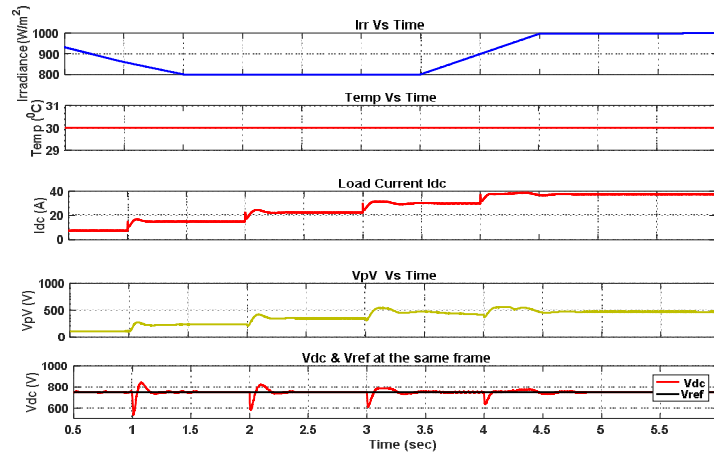

Fig. 5- Output of DC-DC Boost Converter at moderate changes of Solar Irradiance with step load changes at Constant Temperature

Fig. 6 shows the simulation results of the duty cycle before and after correction at moderate changes of solar Irradiance at Constant Temperature and step load changes.

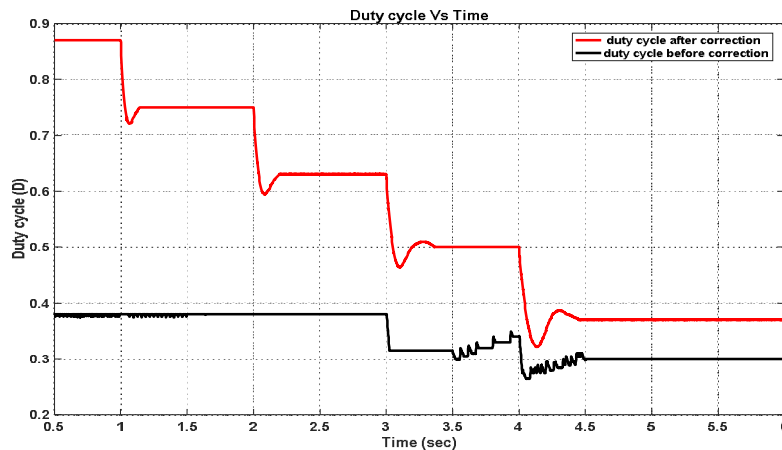

Fig. 6- Duty cycle improvement at step load changes.

Case2: At Constant Temperature but Slow changing of Solar Insolation

Fig. 7 shows simulation results for slow changing of solar Insolation at constant Temperature when step load changes. It is evident that the DC voltage regulator is capable of regaining after change of dc load connected to the DC voltage bus.

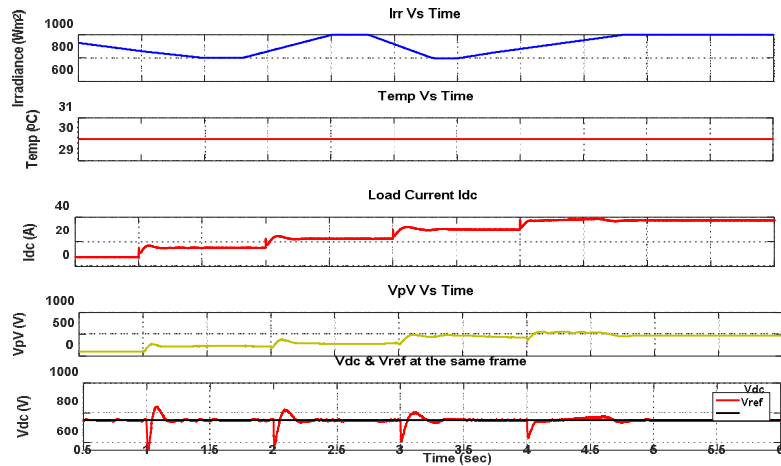

Fig. 7- Output of DC-DC Boost Converter at slow changes of solar Irradiance at step load changes

Fig.8 shows expanded time scale of DC voltage dip showing a voltage dip caused by a step load increase. It can be observed that the regulator is capable to regain DC voltage regulation within 150ms based on the tested Boost DC-DC Regulator embedded with MPPT controller of Solar PV.

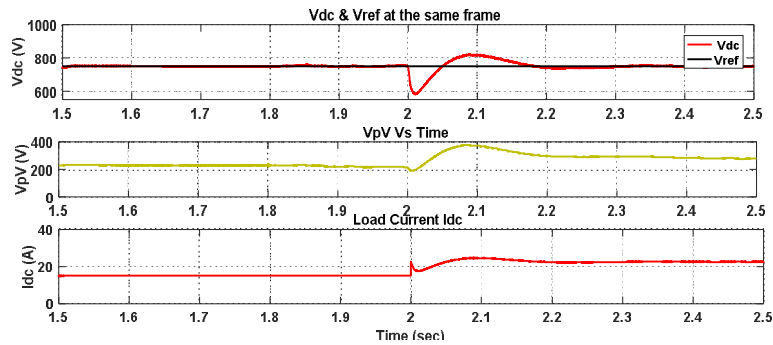

Fig. 8- Voltage dip when step load changes

Case 3: At Constant Load with Varying Solar Irradiance

Fig. 9 shows simulation results for moderate changing of solar Insolation at constant Temperature, At constant load. It is evident that the DC voltage regulator capable to maintain dc Voltage 750V of intended DC bus.

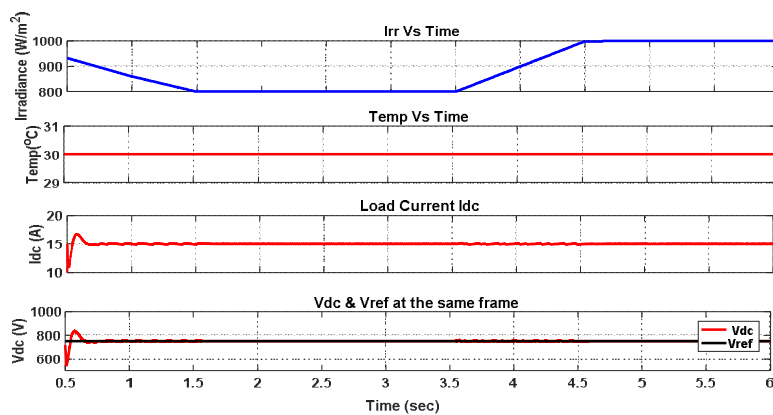

Fig. 9- Output of DC-DC Boost Converter at moderate changes of solar Irradiance at Constant load

Case 4: At Constant Solar Irradiance at step load Changes

Fig. 10 shows simulation result at constant solar Insolation and Temperature when step load changes. The DC voltage regulator and capable of regaining after change of dc load connected to the DC voltage bus.

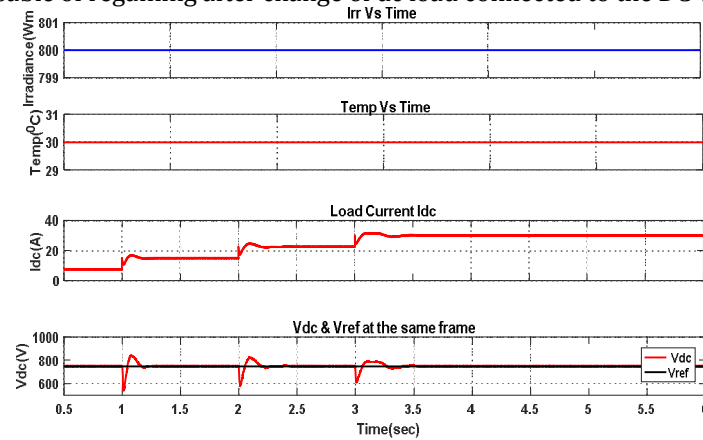

Fig. 10 - Output of DC-DC Boost Converter at constant solar Irradiance and Temperature at step load change

IV. CONCLUSIONS

This research work aimed at designing a constant DC voltage bus embedded with Maximum Power Point Tracking (MPPT) which is used to interface between the Intermittent in nature from renewable energy sources and the loads which require standard DC or AC supply. This research is important as part of global research works on renewable energy sources, conversion and integration technologies. The methodologies used in this research work are modelling of the DC voltage regulation system in off-line simulations of the model through MATLAB/SIMULINK. The results obtained shown that the output voltage retain to reference value against Variation of solar insolation as well as step load changes. The proposed regulator is suitable for synthesis of asynchronous DC busbar which can be used to integrate several renewable energy sources with varying characteristics.

ACKNOWLEDGMENT

This research is supported by Royal Society -Development of International Development (Dfid), UK under the Africa Capacity Building Program Initiative. It is implemented by ACERA consortium: that is University of Leeds, UK; CREEC-Makerere University, Uganda; Dar es Salaam Institute of Technology (DIT), Tanzania and MarienNguabi University-Congo Brazzaville.

REFERENCES

1. Mwinyiwiwa B. M. M, "DC bus voltage regulator for renewable energy based micro grid-application", International Scholarly and Scientific Research & Innovation, vol. 7, no.12 pp.1629-1633, 2013
2. Kewat S, Singh B, Hussain I, "Power management in PV-battery-hydro based standalone microgrid", IET Renewable Power Generation, vol.12 pp.391-398, 2018
3. Iqbal M. M, Islam K, "Design and Simulation of A PV System with Battery Storage Using Bidirectional DC-DC Converter Using Matlab Simulink", International journal of scientific & technology research, vol.6 no.7, pp. 403-410, 2017.
4. Madaci B, Chenni R, Kurt E, Hems K, "Design and control of a stand-alone hybrid power system", Energy Publications LLC, International journal of hydrogen energy, Elsevier Ltd, vol.41 pp.12485 -12496, 2016.
5. Philip J, Jain C, Kant K, Singh B, Mishra S, Chandra A, Al-Haddad. K, "Control and implementation of a standalone solar photovoltaic hybrid system", IEEE Transactions on Industry Applications, vol. 52 no.4, pp 3472-3479, 2016.
6. Adhikari S, Fangxing Li, "Coordinated V-f and P-Q Control of solar Photovoltaic Generators with MPPT and Battery Storage in Micro grids", IEEE Trans. On Smart Grid, vol. 5, no.3, pp. 1270-1281, 2014.